

Speed performance evaluation of BLDC motor based on dynamic wavelet neural network and PSO algorithm

Adel Ahmed Obed¹, Ameer Lateef Saleh², Abbas Kareem Kadhim³

¹Department of Electrical Engineering, Middle Technical University, Iraq

²Department of Electrical Engineering, University of Misan, Iraq

³Department of Electrical Power Engineering Techniques, Middle Technical University, Iraq

+

Article Info

Article history:

Received Dec 31, 2018

Revised Mar 11, 2019

Accepted Jun 17, 2019

Keywords:

Algorithm of PSO

BLDC motor

Dynamic RWNN

Simulation and modeling

ABSTRACT

In this paper, several methods are developed to control the brushless DC (BLDC) motor speed. Since it is difficult to get a good showing by utilizing classical PID controller, the Dynamic Wavelet Neural Network (DWNN) is the proposed work in this paper, with parallel PID controller to obtain a novel controller named DWNN-PID controller. It collects the artificial neural ability of its networks for imparting from motor of BLDC with drive system and the ability of identification for the wavelet decomposition and control of the dynamic system furthermore to have ability for adapting and self-learning. The suggested controller method is utilizing to control the speed of BLDC motor of which supply a better showing than utilizing classical controllers with a wide range of control. The proposed controller parameters are matched continuously using Particle Swarm Optimization (PSO) algorithm. The simulation results based on proposed DWNN-PID controller demonstrate a superior in the stability and performance compared at utilizing classical WNN-PID and conventional PID controllers. The simulation results are accomplished using Matlab/Simulink. It shows that the proposed control scheme has a superior performance.

Copyright © 2019 Institute of Advanced Engineering and Science.
All rights reserved.

Corresponding Author:

Abbas Kareem Kadhim,
Department of Electrical Power Engineering Techniques,
Middle Technical University,
Baghdad, Iraq.
Email: alzubaidy_abbas@yahoo.com

1. INTRODUCTION

The type of BLDC motor has a different of applications in aerospace, automotive, industrial automation, military, household products, computers, etc. because of its higher efficiency, higher torque, lower weight, good efficiency, increasing power density, simple in construction, ease of control and less of maintenance [1, 2]. A BLDC motor is a type of permanent synchronous motor with rotor position feedback. It is generally driven by utilizing a three-phase power semiconductor bridge. The BLDC motor is commutation electronically by its three-phase inverter based on rotor feedback position instead of using the brushes. The position of the rotor is required for motor starting and to supply a proper sequence of commutation to control the power devices in the inverter bridge. The motor consists of a rotor of permanent magnet and stator winding distributed to generate the trapezoidal back-EMF waveforms and are fed with rectangular stator currents, which give a theoretically constant torque. The operation of the BLDC motor established upon the switching the phases by the inverter when turning ON two phases at any time while the rest phase is float where every 60 degrees the two phases are energized and changed sequentially established upon the rotor position [1, 3]. Due to electronic commutation, this type of motor has a more complex control algorithm compared with other motors. To get a complete and exquisite control scheme for BLDC motor, an accurate model is required. The motor model is then the heart of its control drive since the developed torque

related to trapezoidal back emf and current is produced [3]. A rotor position is necessary using sensors to determine the interval of the next commutation. The BLDC motor can be controlled by varying the DC bus voltage or by controlling the duty cycle of the PWM method [5, 6].

The stator has three windings and the rotor has permanent magnets to build up BLDC motor. A trapezoidal shape of the mutual inductance among the two main parts of the motor, stator and rotor, makes a trapezoidal back-emf in the winding of the stator. The analogous three-phase circuit, BLDC motor of star-connected used in this work driven by its three-phase inverter is shown in Figure 1 [1-6].

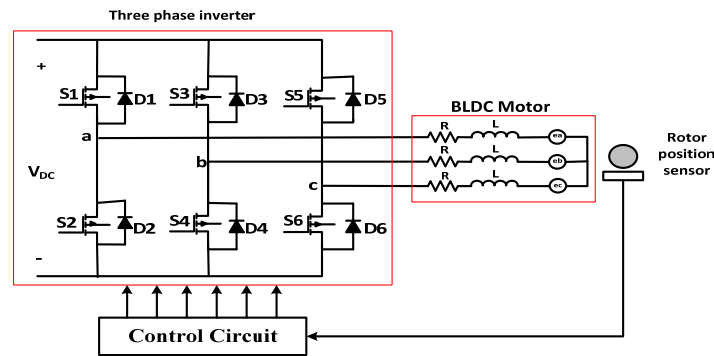

Figure 1. Three-phase inverter with an analogous circuit of BLDC motor drive

The development in the industrial field demand high reliable, high accuracy, rapid response, and good efficient drives; therefore, the speed control of the motor system drive is essential. Classical controlling by PID is stable, simple and easy parameter adjusting. Unless in generality industrial drives with a differing degree of nonlinear, uncertainty in mathematical modeling of the system parameter variability and adjusting parameters of PID controller are difficult, inferior robustness, subsequently, it is not easy to realize the optimal case under level conditions in the true production. To get more accurate and better performance, A Fractional Order PID controller is utilized here to control the speed of this motor. This controller adds flexibility and makes the system more robust thus, enhancing its dynamic performance [6-9].

In the past decades, intelligent control techniques such as fuzzy logic, neural network(NN), wavelet network and the wavelet neural network(WNN) have been used to control the BLDC motor drive system [10,11]. The BLDC motor is considered as multivariable system and non-linear. Therefore it is not easy to realize a fulfill result for BLDC motor utilizing linear classical control methods. A WNN is improved in this paper to achieve high control of accuracy, high performance, and dynamic characteristic and powerful robustness. The WNN-PID controller based on PSO technique is developed here. It merges the ability of the NN for learning from the drive system and the ability of wavelet decomposition to identify and guidance of the dynamic system and also has the guidance of self-adapting and self-learning. Two types of wavelet network are modified in this paper, feed forward wavelet neural network and recurrent wavelet neural network with online tuning optimization using PSO algorithm. Moreover, an improved WNN network with IIR filter is implemented to produce a novelty controller called dynamic wavelet neural network (DWNN). The novelty network has a superior capability to the conventional WNN in an efficient learning mechanism and dynamic response.

In this paper, the fractional order PID (FOPID) controller, wavelet neural network (WNN-PID) controller and the novelty dynamic wavelet neural network (DWNN-PID) controller are used to compare the accuracy and adaptable speed control and hence to minimize effectively commutation in torque ripple within an enormous speed range. In addition, the PSO algorithm is utilizing for tuning and optimizing all the parameters for all controller types utilized in this work.

2. SPEED CONTROL OF BLDC MOTOR BY INTELLIGENT TECHNIQUES

2.1. Fractional order PID controller

The FOPID controller $PI^\lambda D^\mu$ is a stretch of the classical controller of PID based on fraction calculus. The integral and the derivative orders develop the flexibility and guidance the system to less sensitive to changes of parameters. The parameters $PI^\lambda D^\mu$ of the controller can be qualified by this differential equation below [6-9]:

$$u(t) = K_p e(t) + K_i D^{-\lambda} e(t) + K_d D^{\mu} e(t) \quad (1)$$

Here $e(t)$ represents the error of time which is a difference between the required set point and the measured drive output variable; $u(t)$ is the output of that controller. Therefore, the Laplace transfer function of the fractional PID controller will be as:

$$G(s) = K_p + K_i S^{-\lambda} + K_d S^{\mu} \quad (2)$$

2.2. Wavelet neural network

A wavelet neural network (WNNs) is a grade of the neural network which is constructed according to wavelet transform. The combination of this network is between the neural network and wavelet transform, the WNN completely entails the features of the both. It performs a neural network by feed-forward with one output layer and hidden layer based on more or one input. The neurons of the hidden layer that have a wavelet basis to construct activation functions are performed the neural network. These neurons of the neural network are almost called as “wavelons”, whose it's parameters contain coefficients of the dilation wavelet (a) and translation (b) [10-13]. In WNN, both the dilation and the translation (position) are optimized as well as the weights. Each certain signal $f(t)$ of this network is approximated by popularizing a linear collection of a suit daughter wavelets $\psi_{a,b}$, where $\psi_{a,b}$ are created by dilation and translation from the mother wavelet ψ as below:

$$\psi_{a,b} = \psi\left(\frac{x-b}{a}\right), \quad (3)$$

The wavelet neural network output is given by:

$$y = \sum_{n=1}^N w_N \psi_{a_N, b_N} \quad (4)$$

where w_N represents the heaviness of the n^{th} node in the hidden layer to the output later. a_N and b_N are the dilation and translation factors respectively; x represents the input of the network; $\psi_{a,b}$ is the wavelet function. This paper uses the Mexican hat wavelet as a wavelet function, which is given as follows:

$$\psi(x) = (1 - x^2) e^{-\frac{x^2}{2}} \quad (5)$$

RWNN is similar to that feed forward WNN with feedback connections. The feedback is obtained via linking signal of the output stratum to the input stratum or in one stratum that is called slightly feedback. The input of the wavelet network is consist of previous input of the system samples $x_{(M)}$ and the output of system $y(t)$ as appear in Figure 2. A size of inputs to A WNN is increased with increasing the system in order to be reduplicated. Therefore, each layer output can be deemed as [11-14]:

$$\psi_N = \psi\left(\frac{u_N - b_N}{a_N}\right) \quad (6)$$

This layer inputs for time t is denoted as:

$$u_N(t) = x_N(t) + \psi_N(t-1) * \phi_N \quad (7)$$

where ϕ_N indicated the self-feedback loop weight. The output of the network is then:

$$y = \sum_{N=1}^N w_k \psi\left(\frac{u_N - b_N}{a_N}\right) \quad (8)$$

$$u(t) = x(t - D_i) + y(t - D_o) * r_N \quad (9)$$

where x is the wanted signal, N is the hidden stratum neurons number, w_N : the output weight, D_o, D_i : the delay number for the output and input network and r_N : the output feedback loop weight.

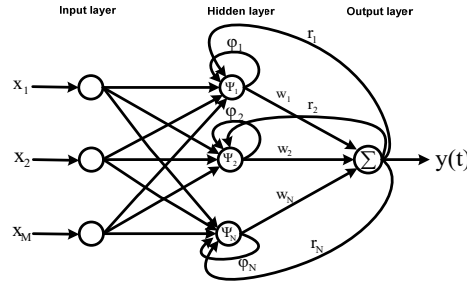

Figure 2. Structure of RWNN

The IIR filters can be accomplished as an analog form or digital form filters. Design of digital IIR filters which are tardily dependent on that of their analog counterparts because there is a wealth of resources, works and straightforward design methods related analog feedback filter design. The general equation of an IIR filter can be expressed as [15].

$$H(z) = \frac{d_0 + d_1 z^{-1} + \dots + d_N z^{-N}}{1 + c_1 z^{-1} + \dots + c_M z^{-M}} \tag{10}$$

$$H(z) = \frac{\sum_{k=0}^N d_k z^{-k}}{1 + \sum_{k=1}^M c_k z^{-k}} \tag{11}$$

where c_k and d_k are the filter coefficients. For the implementation of the above equation the following difference equation is needed:

$$y(n) = \sum_{k=0}^N c_k x(n - k) - \sum_{k=1}^M d_k y(n - k) \tag{12}$$

which is of order $\max[N, M]$. A block diagram for the IIR filter with $N=2, M=2$ is shown in Figure 3.

The WNN is a regional network where the function of output is well focused in both frequency domain and time domain. Moreover, a dual local network may be completed by integrating this WNN design cascaded with a regional Infinite Impulse Response (IIR) [16, 17]. Figure 3 shows the structure that approximate any wanted signal $y(t)$ with popularizing a linear synthesis of a series of daughter wavelets $\Psi_{aN, bN}$ cascaded by the topical IIR recurrent networks. The sacrificial network signal $\hat{y}(t)$ can be given by:

$$\hat{y}(t) = \sum_{i=0}^M c_i y(t - i) + \sum_{j=1}^N d_j \hat{y}(t - j)v(t) \tag{13}$$

$$y(t) = \sum_{N=1}^N w_k \Psi_{aN, bN} \tag{14}$$

where w_k represents the k th coefficients of weight, M and c_i are the feed forward delays number and the IIR filter coefficients, respectively, N and d_j are the feedback delays number and the coefficients of the recursive filter, respectively. The signals $v(t)$ and $x(t)$ are the co-input and input to the system at time t , respectively. Co-Input $v(t)$ is commonly preserved small because of stability goal in the feedback. The dilation and translation factors, weights linkage for WNN, coefficients of the IIR filter and the parameters of PID are learning and tuning on-line in an algorithm of PSO.

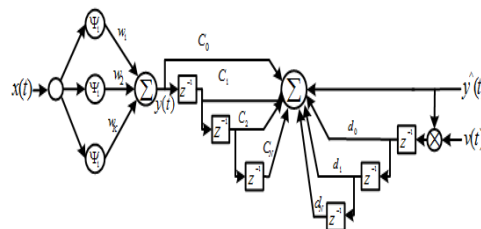

Figure 3. WNN with IIR filter structure

2.3. Technique of algorithm for particle swarm optimization

PSO is a new inhabitation based evolutionary computation which turns on the social behavior principle like fish schooling or bird flocking. PSO technique is certified from researching on swarms like fish instruction or bird crowding. Due to the results of the research for a birds group, birds can detect food by congregating (not within each particular). Thus, any guide in the inhabitation called a particle, which is named swarm brilliance [7, 11]. The algorithm of PSO is a type of the evolutionary reckoning methods for resolving problems of optimization. This way can be utilized to the non-linear optimization problem that guaranty constraints wanting the cost function graduate. The considered cost functions are established upon the desired criterion. The chosen of the criteria depends on the controller and the drive. The basic principle of the PSO algorithm can be described through the flowchart below. Where each particle in the PSO algorithm has two primary operators' velocity and position that updated during its flight. For a multidimensional trouble, the position and velocity for any particle in the swarm are updated by utilizing the following equations:

$$v_i^{k+1} = w * v_i^k + c_1 * R_1 * (lbest_i - x_i^k) + c_2 * R_2 * (gbest_i - x_i^k) \quad (15)$$

$$x_i^{k+1} = x_i^k + v_i^{k+1} \quad (16)$$

where v_i^k , x_i^k are the speed instant and position of particle i at iteration k respectively, w is the weight of inertia, c_1 and c_2 are the constants of acceleration and R_1 , R_2 represent random variables between 0 and 1.

$$w = w_{\max} - \frac{(w_{\max} - w_{\min})}{iter_{\max}} \quad (17)$$

where w_{\max} and w_{\min} represent the weights of elementary and eventual, $iter$ represents the present iteration time and $iter_{\max}$ is its iterations maximum number. By this paper, a multi-fitness function is utilized to detect the optimal settlement with a lower error of speed based on the Integral of Squared Error (ISE) criterion and maximum overshoot (M_p) criterion as below:

$$\text{Cost function} = \min(\text{ISE}) + \min(M_p) \quad (18)$$

$$\text{ISE} = \int e^2(t) dt \quad (19)$$

$$M_p = n_{\max} - n_{\text{ref}} \quad (20)$$

$$e(i) = n(i) - n_{\text{ref}}(i) \quad (21)$$

where n is the present speed, and n_{ref} is the required value of the speed. In this paper, this method is used to find the optimal value for the controllers' parameters to control BLDC motor speed. Referring to the on the top, the algorithm of PSO can be specified as a flowchart shown in Figure 4.

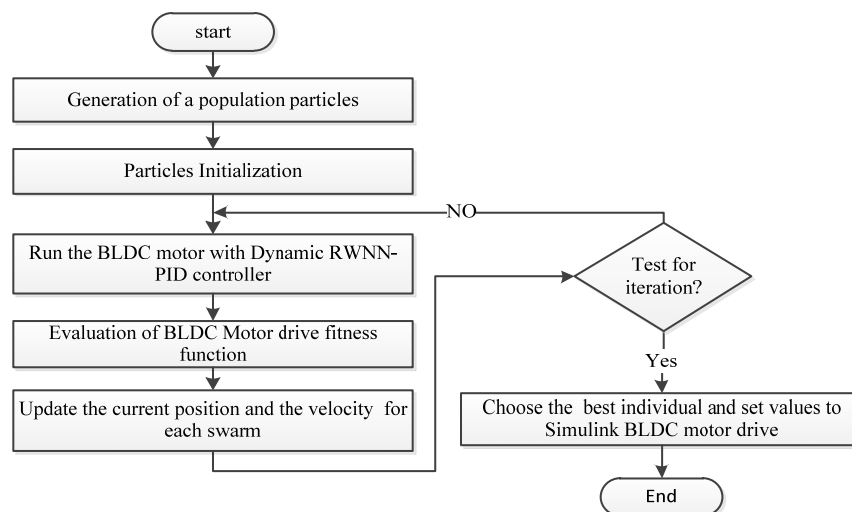

Figure 4. Flow chart of PSO

3. CONTROL OF SPEED FOR BLDC MOTOR BASED ON PROPOSED DYNAMIC WNN CONTROLLER

The schematic diagram of the BLDC motor drive based on dynamic WNN controller is shown in Figure 5. It consists of BLDC motor driven utilizing three-phase inverter with a control circuit to provide the proper sequence to the motor. A step-down chopper utilized to control the input voltage of the inverter according to the novel dynamic WNN controller with IIR filter. The PSO algorithm is used to tuning all the coefficients of the proposed controller.

The rotor speed is directly controlled by stator voltage. Therefore the difference between the set speed and rotor speed which detected by the rotor position technique is used to drive the controller. The rotor position scheme detected by the rotor position strategy, it's to generate the proper commutation signals for switching the inverter. Here the output of the dynamic WNN-PID controller controls the duty cycle of the step-down chopper. This controller-based on PSO algorithm is utilized to control BLDC motor speed in an extensive range. It provides better showing than classical PID controller and classical WNN-PID controller as will be shown in the results.

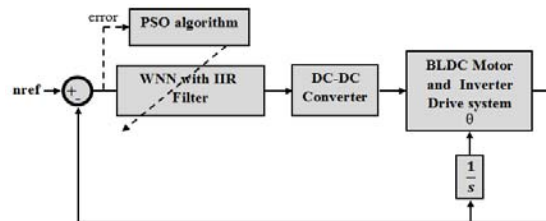

Figure 5. Schematic diagram of BLDC motor with the proposed controller

4. SIMULATION RESULTS FOR A PROPOSED DWNN-PID CONTROLLER WITH IIR FILTER

The overall BLDC motor Simulink model with its drive system is given in Figure 6. The Simulink model of this motor is constructed in Matlab from its mathematical equation. The overall drive system of BLDC motor based on DWNN-PID controller with IIR filter is constructed in Simulink/Matlab program, version 2015b with sampling period that assumed in this model is 1s. The simulation results show that the DWNN is capable to drive the system with a larger number of iterations compared with the conventional WNN and by employing the same wavelets functions type and gives better performance than the other methods.

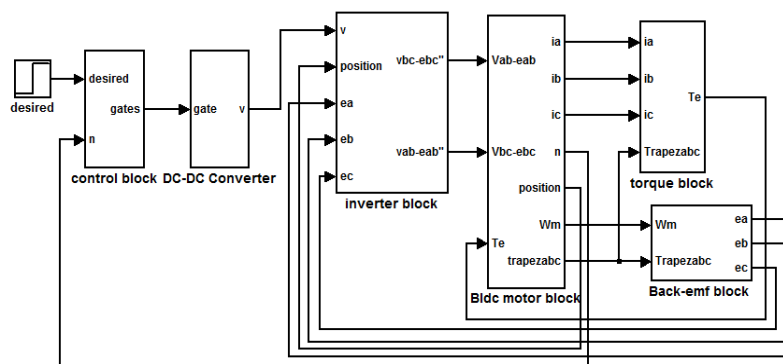

Figure 6. Simulink model of BLDC motor drive

Figure 7 (a) shows the step change for a BLDC motor speed response. The change of the step in speed for a reference is 500 rpm and increases 500rpm any 0.2sec. Figure 7 (b) shows the speed response with no load and full load (2N.m) is added at t=0.4sec at reference speed is 2000 rpm. The no load and full load condition for the developed torque is shown in Figure 7 (c). Figures 8 (a, b) shows the current in phase A and the back emf voltage in phase A respectively; Figures 9 (a, b) shows the line voltage (v_{ab}) and the

position signal of the rotor respectively for that same conditions at no load and full load. These results ensure the validity of the model, the speed, current and torque reach to its new values quickly. The back emf reveals the trapezoidal shape and the rotor position realizes six sectors during the 2π period.

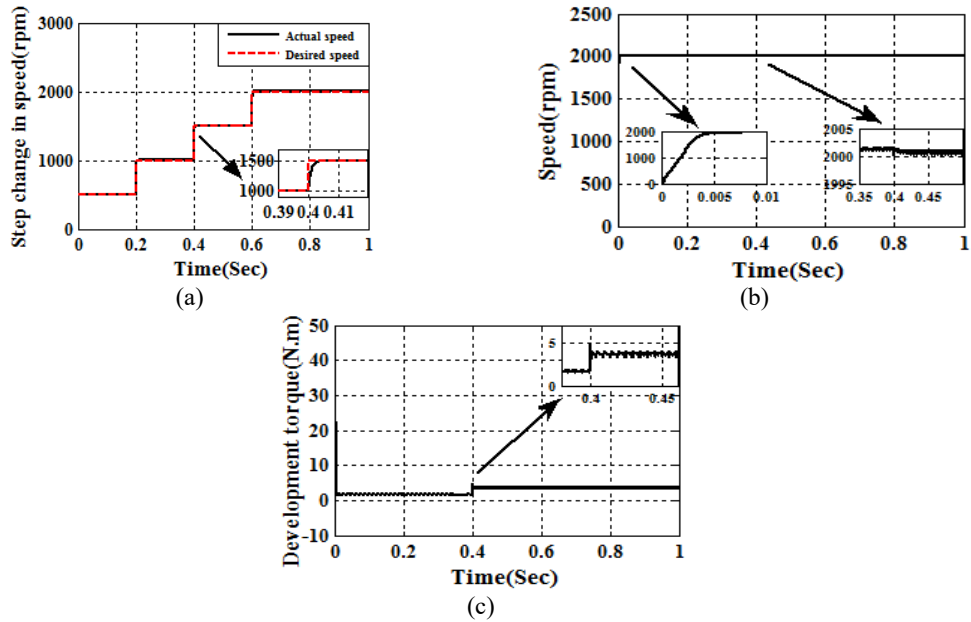

Figure 7. (a) A step change in set speed. (b) Speed response for direct starting. (c) Developed torque for no load and load conditions.

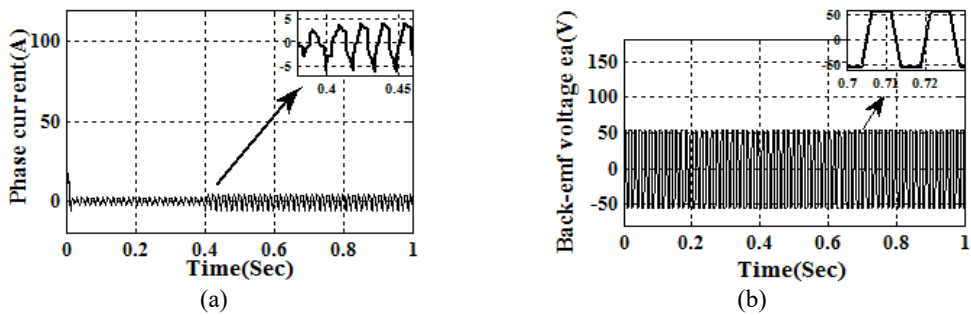

Figure 8. (a) Phase A current of BLDC motor. (b) Phase A back-emf voltage of BLDC motor.

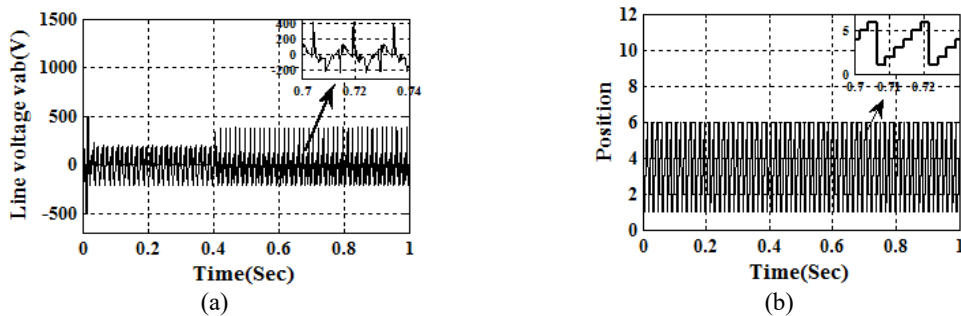

Figure 9. (a) Line voltage (v_{ab}) of BLDC motor. (b) Rotor position signal of BLDC motor.

5. COMPARISON OF DIFFERENT CONTROL METHODS FOR SPEED CONTROL OF A BLDC MOTOR DRIVE

A comparison among various wavelet neural network schemes, fractional and classical PID controllers is illustrated in Table 1. From This comparison, as a result, shows that a proposed DWNN controller with IIR filter is the perfect way to beat on the nonlinearity in this system with good reliability, additional powerful and better achievement compare than another way as appeared in Figure 10 with load change conditions.

Table 1. A comparison in speed performance with different control methods

Performance	Rise time	Settling time	Steady state error	Overshoot %
WNN-PID	0.0035	0.03	3×10^{-3}	8×10^{-2}
RWNN-PID	0.0038	0.04	2×10^{-3}	0
DWNN-PID	0.003	0.03	2.5×10^{-4}	0
RDWNN-PID	0.005	0.02	2×10^{-3}	4×10^{-3}
FOPID	0.015	0.25	2×10^{-3}	5×10^{-2}
PID	0.03	0.35	5×10^{-3}	5.6×10^{-2}

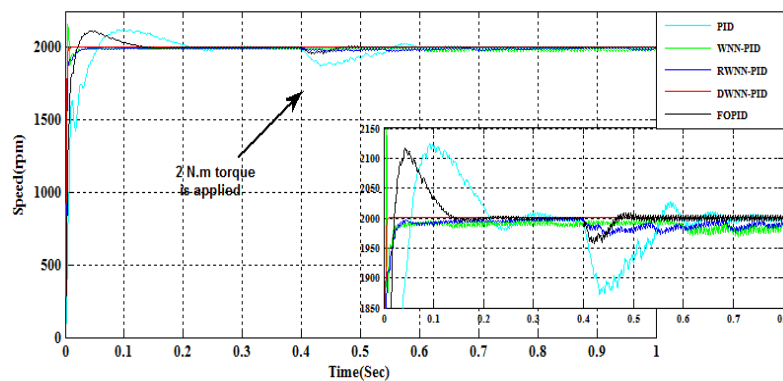

Figure 10. Speed performance with different control methods and with load change conditions.

6. CONCLUSIONS

In this paper, Classical PID, FOPID, WNN-PID, RWNN-PID, DWNN-PID and RDWNN-PID controller has been utilized to control the speed of BLDC motor. PSO technique has been used for tuning the parameters of the suggested controller. The comparison between the different methods shows that a proposed DWNN-PID controller is the better method to control the speed of BLDC motor and the results shows that the BLDC motor performance under different operating conditions is improved. Moreover, a drive system provides a robust and flexible due to the effect of changing in set speed and load torque.

REFERENCES

- [1] R. Narmada, M. Aromassalane, "Design and performance evaluation of fractional ORDER controller for brushless DC motor," *International Journal of Electrical Engineering and Informatics*, vol. 6, no. 3, pp. 606-617, 2014.
- [2] S. Khubalkar, A. Chopade, A. S. Junghare, M. V. Awre, "Design and tuning of fractional order PID controller for speed control of permanent magnet brushless DC motor," *IEEE International Conference on Control, Measurement and Instrumentation (CMI)*, 2016.
- [3] C. Lucas, F. Tootoonchian, Z. Nasiri-Gheidari, "Multi-objective design optimization of a linear brushless permanent magnet motor using particle swarm optimization," *Iranian Journal of Electrical & Electronic Engineering*, vol. 6, no. 4, 2010.
- [4] Tashakori A., Ektesabi M., Hosseinzadeh N., "Modeling of BLDC motor with ideal back-emf for automotive applications," *Proceedings of the World Congress on Engineering*, vol. 2, 2011.
- [5] Adel A. Obed, Abbas K. Kadhim, "Speed and current limiting control strategies for BLDC motor drive system: A comparative study," *International Journal of Advanced Engineering Research and Science*, vol. 5(2), pp.119-130, 2018.

- [6] L. Saleh, A. A. Obed, "Speed control of brushless DC motor based on fractional order PID controller," *International Journal of Computer Applications*, vol. 95, no. 4, pp. 1-6, 2014.
- [7] L. Saleh, M. A. Hussain, S. M. Klim, "Optimal trajectory tracking control for a wheeled mobile robot using fractional order PID controller," *Journal of University of Babylon, Engineering Sciences*, vol. 26, no. 4, pp.292-306, 2018.
- [8] Akram H. Ahmed, Abd El Samie B. Kotb, Ayman M.Ali, "Comparison between fuzzy logic and PI control for the speed of BLDC motor," *International Journal of Power Electronics and Drive System (IJPEDS)*, vol. 9, no. 3, pp. 1116-1123, Sep. 2018.
- [9] Rinku S., Subhransu P., Gagandeep K., "Design of fractional order PID controller for speed control of DC motor," *International Journal of Scientific and Research Publications*, vol. 2, 2012.
- [10] Maohua Zhang, Changliang Xia, Yang Tian, Dan Liu, Zhiqiang Li, "Speed control of brushless DC motor based on single neuron PID and wavelet neural network," *IEEE International Conference on Control and Automation Guangzhou, China*, 2007.
- [11] Adel A. Obed and Ameer L. Saleh, "Speed control of BLDC motor based on recurrent wavelet neural network," *Iraq J. Electrical and Electronic Engineering*, vol.10, no.2, pp.118-129, 2014
- [12] Sung Jin Yoo, Jin Bae Park, Yoon Ho Choi, "Direct adaptive control using self-recurrent wavelet neural network via adaptive learning rates for stable path tracking of mobile robots," *IEEE American Control Conference. Proceedings of the*, vol.1. pp. 2848-2852, 2005.
- [13] Sung Jin Yoo, Yoon Ho Choi, Jin Bae Park, "Generalized predictive control based on self-recurrent wavelet neural network for stable path tracking of mobile robots: Adaptive learning rates approach," *IEEE Transaction's on Circuits and Systems I*, vol.53, pp. 288-293, 2006.
- [14] L. Saleh, B. A. Obaid, A. A. Obed, "Motion control of linear induction motor based on optimal recurrent wavelet neural Network-PID controller," *International Journal of Engineering & Technology*, vol.7, no.4, pp. 2028-2034, 2018.
- [15] Ranjit Singh, Sandeep K. Arya, "Optimization of IIR digital filters using particle swarm optimization," *IEEE International Conference on Communication, Information & Computing Technology (ICRICT)*, Mumbai, India, pp. 1-7, 2012.
- [16] Cheng-Jian Lin, Chi-Yung Lee, Cheng-Chung Chin, "dynamic recurrent wavelet network controllers for nonlinear system control," *Journal of the Chinese Institute of Engineers*, vol. 29, no. 4, pp. 747-751, 2006.
- [17] Adel A. Obed, Abbas K. Kadhim, "Multi-resolution wavelet PID speed and current controllers of BLDC motor based on invasive weed optimization technique," *International Journal of Applied Engineering Research*, vol. 13, no.8, pp. 6234-6243, 2018.