

PAPER • OPEN ACCESS

## Modeling and Simulation of A Low Cost Perturb& Observe and Incremental Conductance MPPT Techniques In Proteus Software Based on Flyback Converter

To cite this article: Ameer L. Saleh *et al* 2020 *IOP Conf. Ser.: Mater. Sci. Eng.* **881** 012152

View the [article online](#) for updates and enhancements.

# Modeling and Simulation of A Low Cost Perturb& Observe and Incremental Conductance MPPT Techniques In Proteus Software Based on Flyback Converter

Ameer L. Saleh<sup>1</sup>, Adel A. Obed<sup>2</sup>, Zainab Abdullah Hassoun<sup>3</sup>, Salam J. Yaqoob<sup>4</sup>

<sup>1</sup> Department of Electrical Engineering, University of Misan, Iraq.

<sup>2</sup> Department of Electrical Engineering Technical, Baghdad, Iraq.

<sup>3</sup> The Islamic university, Najaf- Iraq.

<sup>4</sup> Popular Mobilization, Prime Minister Office, Iraq.

<sup>5</sup> Ministry of Science and Technology, Central Laboratories Directorate.

E-mail: <sup>1</sup> usamah.barrak@yahoo.com (Corresponding author), <sup>2</sup> Mursal673@gmail.com, <sup>3</sup> marwantahir90@gmail.com, <sup>4</sup> sabah.kh1974@yahoo.com, <sup>5</sup> mmhsh\_1988@yahoo.com

**Abstract.** A photovoltaic (PV) panel that extracted the electrical energy from the sunlight energy is as nonlinear in nature with respect to the weather conditions such as solar irradiance and ambient temperature. Hence, the PV panel characteristics are exhibited a nonlinear P-V and I-V characteristics. Therefore, a one-point in the nonlinear PV characteristics at which the power is maximum. For this reason, the maximum power of the PV panel can be extracted using maximum power point tracking (MPPT) technique, the efficiency of the PV panel is increased. This MPPT technique is implemented using a suitable DC/DC converter linked with a corrected load resistance. In this paper, isolated flyback DC/DC converter is used to implement the MPPT techniques of low cost perturb& observe (P&O) and incremental conductance (INC) algorithms that represent the main controller in the PV system. The Proteus software is used to modeling and simulate the PV panel model that integrated with MPPT under variable cell temperature and solar irradiance and its control. Each technique is simulated with the PV model, flyback converter and a resistance load in order to the comparison between their performances. The results show that the P&O technique is tracked faster than the INC technique but the fluctuation is higher. On other hand, more power form the PV panel is obtained in INC technique which is lead to that the INC is more efficient than the P&O algorithm.

**Keywords:** Flyback converter, Proteus software, MPPT controller, incremental conductance (INC) algorithm, Perturb and observe (P&O) algorithm.

## 1. Introduction

In the last decades, renewable energy sources have gained a significant role in electric power generation. Nowadays, solar energy is counted as one of the significant common renewable energy sources that have been acquired prodigious popularity due to daily free-available, environment-friendly, and not have more mechanical supports [1,2]. However, solar energy suffers from some drawbacks such as low efficiency and produces variable output, and not a reliable source due to the output power of solar cells depends on solar irradiation and temperature of cells. In order to vanquish these drawbacks, an MPPT technique is



used to optimize the output power[3]. The MPPT technique is one of the most effective methods in PV modules which utilized to enhance the efficiency and extracted the maximum possible power of the PV panel by an optimizing the operating voltage and current[4,5]. An MPPT controller integrated with a DC-DC converter that linked to a suitable load resistance, and then controller algorithm is changed the duty cycle of this converter to make the system operate at its maximum power point (MPP). Many MPPT techniques have been suggested and reviewed recently [5-7]. The most common techniques that implemented the MPPT controller are Perturb and Observe (P&O), Incremental Conductance (INC), voltage-feedback methods etc. these techniques are used for this purpose due to the simplicity[8,9]. In this paper, P&O and INC techniques are utilized to adjust the duty cycle of an isolated flyback converter to maximize the power output from the PV module. The flyback converter is a good solution for MPPT tracking for a PV system[10,11].

## 2. Mathematical model of PV Module

The equivalent circuit that is shown in Figure 1, represents a PV cell model. This model is called a one-diode model [5,8]. It is based on a supposition that the reassembly loss in the depletion region is negligible. The one-diode model is widely utilized for most PV applications due to its simplicity. Since, for modelling and simulation a practical PV cell, series, and parallel resistance must be included. In this paper, the approach adopted as been to utilize a single-diode model to represent the PV cell as shown in Figure 1. The I-V characteristics for this model circuit can be specified by the following equations [11-13]:

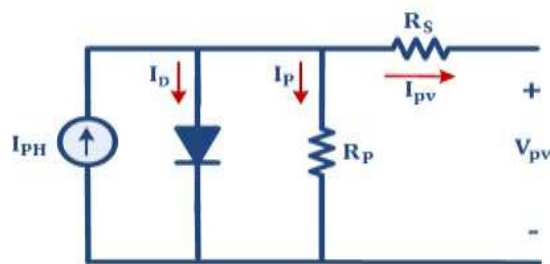

**Figure 1.** The single-diode model

$$I_{pv} = I_{PH} - I_D - I_p \quad (1)$$

$$I_D = I_o e^{(V_D/\alpha V_T - 1)} \quad (2)$$

$$V_T = kT/q \quad (3)$$

$$V_{pv} = \alpha V_T \ln \left[ \frac{I_{PH} - I_{pv}}{I_o} + 1 \right] \quad (4)$$

Where,  $V_T$  is “the temperature voltage”,  $V_{pv}$  is “the PV voltage”,  $V_D$  is “the diode voltage”,  $\alpha$  is “the diode goodness”,  $I_o$  is “the reverse saturation current of the diode”,  $I_{pv}$  is “the output current of the PV cell”,  $I_{PH}$  “photogenerated current”,  $I_{sc}$  is “the short circuit cell current”,  $I_D$  is “the diode current”,  $k$  is “Boltzmann’s constant”,  $q$  is “the electron charge”. Also,  $R_s$  is “the series resistance of PV cell”,  $R_p$  is “the parallel resistance of PV cell”,  $T$  is “the PV cell temperature”. From eq. 2 and according to Fig.1, the output current of a PV panel is given by:

$$I_{pv} = I_{PH} - I_o \left[ \exp \left( \frac{q(V_{pv} + R_s I_{pv})}{\alpha k T} \right) - 1 \right] - \frac{V_{pv} + R_s I_{pv}}{R_p} \quad (5)$$

In the perfect state  $R_s$  would be zero and  $R_p$  infinite. Although, this ideal situation is not imaginable and manufacturers try to decrease the effect of both resistances to ameliorate their products. Table 1 depicts the electrical parameters of the SR-60W PV panel utilized in this work.

**Table 1.** Electrical parameters of the SR-60SW PV panel under STC.

Quantity	Value
$V_{mpp}$	14.7 V
$I_{mpp}$	4A
$P_{mpp}$	60W
$V_o$	19.26V
$I_{sc}$	4.55A
$K_i$	$(0.03 \pm 0.015)$ percent/ $^{\circ}C$
$K_v$	$-(93 \pm 10)$ mV/ $^{\circ}C$
$N_s$	36

### 3. Flyback Converter Analysis

There are various techniques of DC-DC converters generally utilized in PV systems [8,9]. A flyback converter is a kind of buck-boost converter with an isolated transformer and an inductor split, the transformer polarity utilized for voltage isolation between source. The uncontrolled dc voltage from the PV panel is given as input to the flyback converter. The MOSFET switch is linked to the primary side of the isolated transformer to maintains the reference output voltage through the gate drive circuit[12-14]. The transformer secondary side winding voltage is rectified and filtered by using a diode and capacitor. The structure of the flyback converter is shown in Figure 2. The output voltage  $V_o$  equation of the flyback converter is given as:

$$V_o = \frac{N_2}{N_1} \cdot \left( \frac{D}{1-D} \right) \cdot V_i \quad (6)$$

where  $\frac{N_2}{N_1}$  is the transformer turns-ratio,  $D$  is the duty cycle and  $V_i$  is the input flyback voltage.

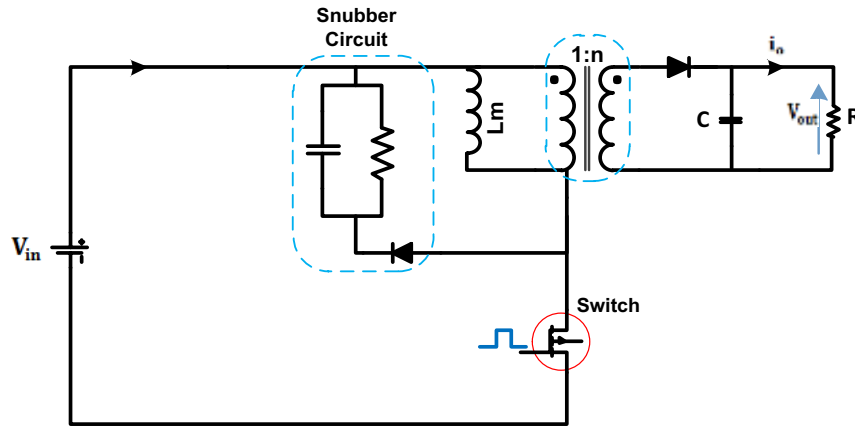

**Figure 2.** The structure of the flyback converter.

#### 4. MPPT Control Techniques

The MPPT controller is a power electronic converter (DC/DC converter) with a special control algorithm that optimizes the interconnection of the PV module and the resistance load. Hence, the MPPT technique is utilized to get the peak power from the PV panel at any load condition. In this paper, the isolated flyback DC-DC converter is utilized with the MPPT technique. The input resistance of the flyback converter that seen by the PV module is changed by changing the duty ratio and therefore it matches the load resistance to extract the maximum power from the PV module. Furthermore, I-V and P-V characteristics of a PV panel are shown in Figure 3. Based on these curves the MPPT controller is worked by trucked the maximum power point that achieved in the intersection point for maximum values of current and voltage, and then the optimal power is reached. Today, there are several MPPT technique s obtainable in the world market, which can be categorized into two classes: direct and indirect technique s [2,4,7]. The direct techniques are based on the principle that the slop in the P-V characteristics or any alternative relationships derived from this principle. several direct MPPT techniques are listed as:

1. Incremental Conductance (INC) technique.
2. Perturb and Observe (P&O) technique.
3. Fuzzy Logic Control (FLC) technique.
4. Slid Control technique.

While the Indirect technique s are not established upon the principle of the direct technique s, rather, it depends on the principle of estimating the MPP from irradiance, temperature, empirical data, or equivalent mathematical terms. Several indirect MPPT technique s are listed below:

1. Curve fitting technique.
2. Lookup table technique
3. Constant voltage technique
4. Fractional open circuit voltage technique
5. Fractional short circuit current technique
6. Neuro-fuzzy or ANSIS-reference model technique

There are some criteria to select the proper MPPT technique according to cost, sensors required, response time or convergence speed, and complexity. For this reason, in this paper, two simple techniques will be

studied and explained which are incremental conductance technique (INC), perturb and observe (P &O) technique.

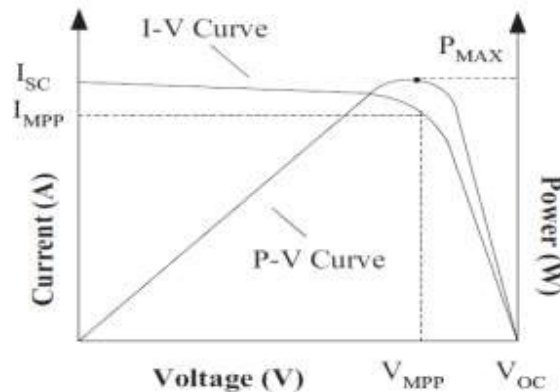

**Figure 3.** Typical I-V and P-V characteristics of PV panel.

#### 4.1. Description of P&O technique

The P&O technique is the most extensively utilized MPPT technique due to its low cost and simplicity. A small perturbation is inserted into the algorithm as shown in Figure 4. In the beginning, the voltage, current, and the corresponding power  $P_1$  of the PV panel are obtained, and then the operating voltage of the PV module is perturbed by a slight increment and the producing new power  $P_2$ . After that, the change in power  $\Delta P$  is measured through the difference between  $P_1$  and  $P_2$ . If the difference is a positive sign then the perturbation of the operating voltage stir the operating point nearby to MPP [1,7]. In this state, maximum power point  $P_{mpp}$  is obtained and identical voltage  $V_{mpp}$  can be measured [8]. Consequently, the additional perturbation can be introduced in the same direction to reach the MPP. On another hand, if the difference is negative, the algorithm makes the decision to reverse the direction. The change in power should be in the same direction as the change in voltage for further perturbation in the same direction. If they follow the opposite trend, the voltage reference should be reversed. This process should be reiterated until the peak power from the PV panel is detect and extracted. The vibration in this algorithm can be reduced with lesser perturbation steps. Thus, by using small steps cause the slow response of the MPP tracker. This problem can be avoided by utilizing variable perturbation steps [8,12]. This technique has some advantages such as simplicity and popularity. However, it still has some drawbacks like power loss due to this perturbation and fails to track the power under different atmospherically conditions. The flowchart of the P&O MPPT technique is presented in Figure 5.

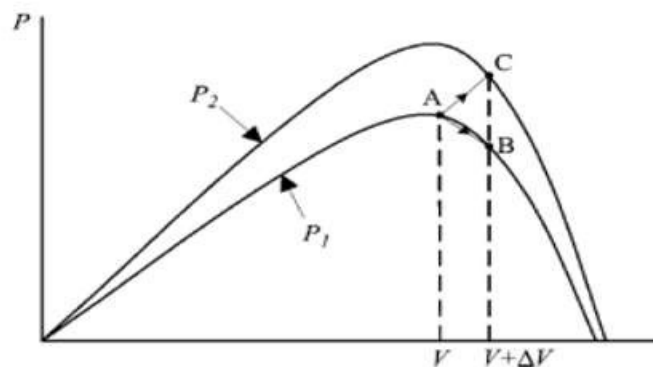

**Figure 4.** Divergence of hill climbing for the P&O technique.

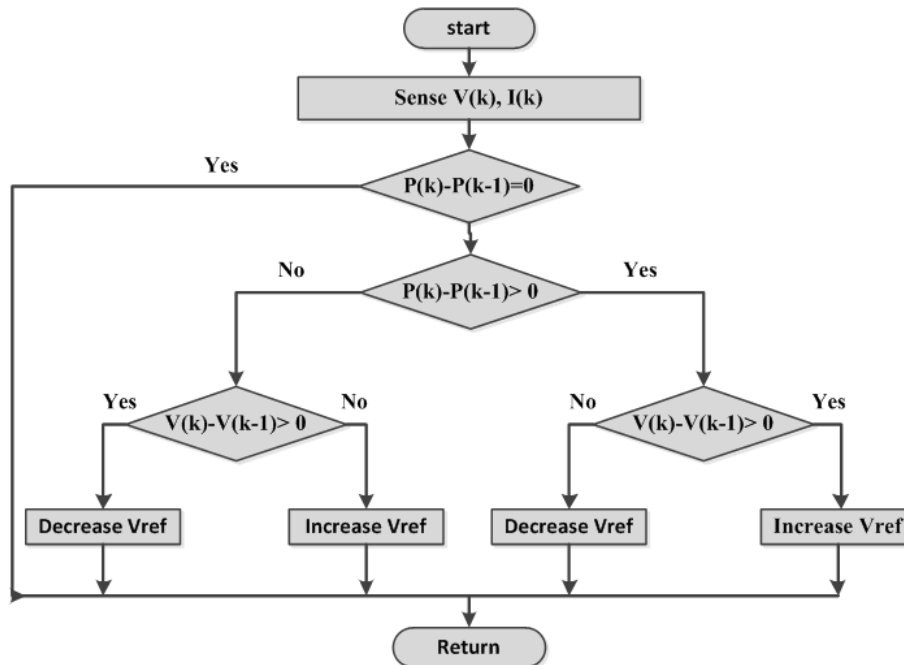

**Figure 5.** The P&O MPPT algorithm.

#### 4.2. Description of INC technique

The fundamental goal of the INC technique is to detect the derivative relationship between the PV power and voltage which can be expressed as  $dP/dV$ . The peak power can be accomplished when  $dP/dV$  reached to zero. The INC algorithm enumerates  $dP/dV$  depends on the incremental of for the PV power and voltage. For this reason, if  $dP/dV$  is not reached to zero, this MPPT algorithm will set the PV voltage step by step until  $dP/dV$  reaches to zero, and then the PV panel achieved its maximum output power [2,6,7]. The major disadvantage of this technique is an output instability which is occurred due to the utilize of derivative. In addition, the derivative process under low solar irradiance levels becomes complicated and results are unsatisfactory [8,14]. When the  $(dP/dV)$  is in fact zero, can be expressed according to the following equations:

$$\frac{dP}{dV} = \frac{d(VI)}{dV} = I + V \frac{dI}{dV} = 0 \text{ at the MPP} \quad (7)$$

Rearranging eq. (7) as follows:

$$-\frac{I}{V} = \frac{dI}{dV} \quad (8)$$

where  $dV$  and  $dI$  are the increments of PV voltage and current, respectively. The essential INC rules can be obtained from the P–V characteristics as presented in Figure 6, and can be written as:

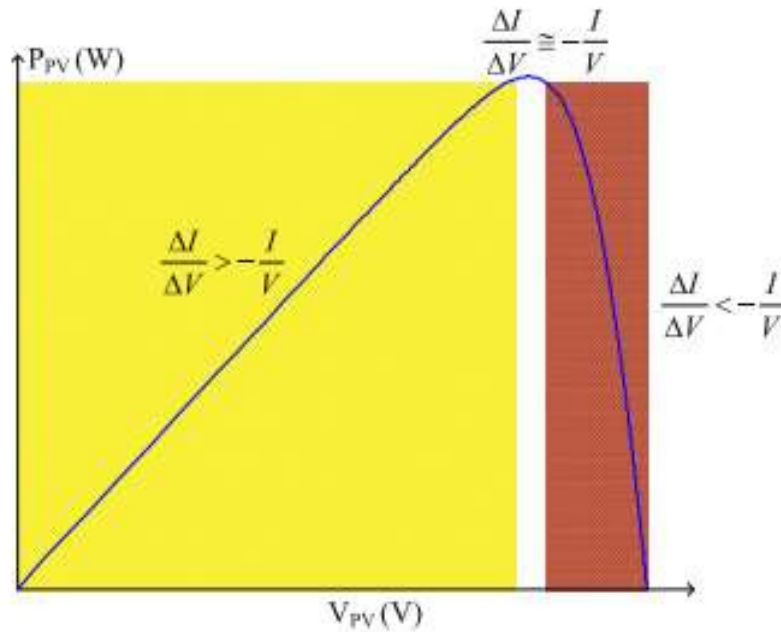

**Figure 6.** P-V characteristic of PV for the INC technique.

$$\begin{cases} \frac{dI}{dV} = -\frac{I}{V} & \text{At MPP} \\ \frac{dI}{dV} > -\frac{I}{V} & \text{Left of MPP} \\ \frac{dI}{dV} < -\frac{I}{V} & \text{Right of MPP} \end{cases} \quad (9)$$

According to eq.(9), the flowchart of the INC MPPT algorithm is presented in Figure 7.



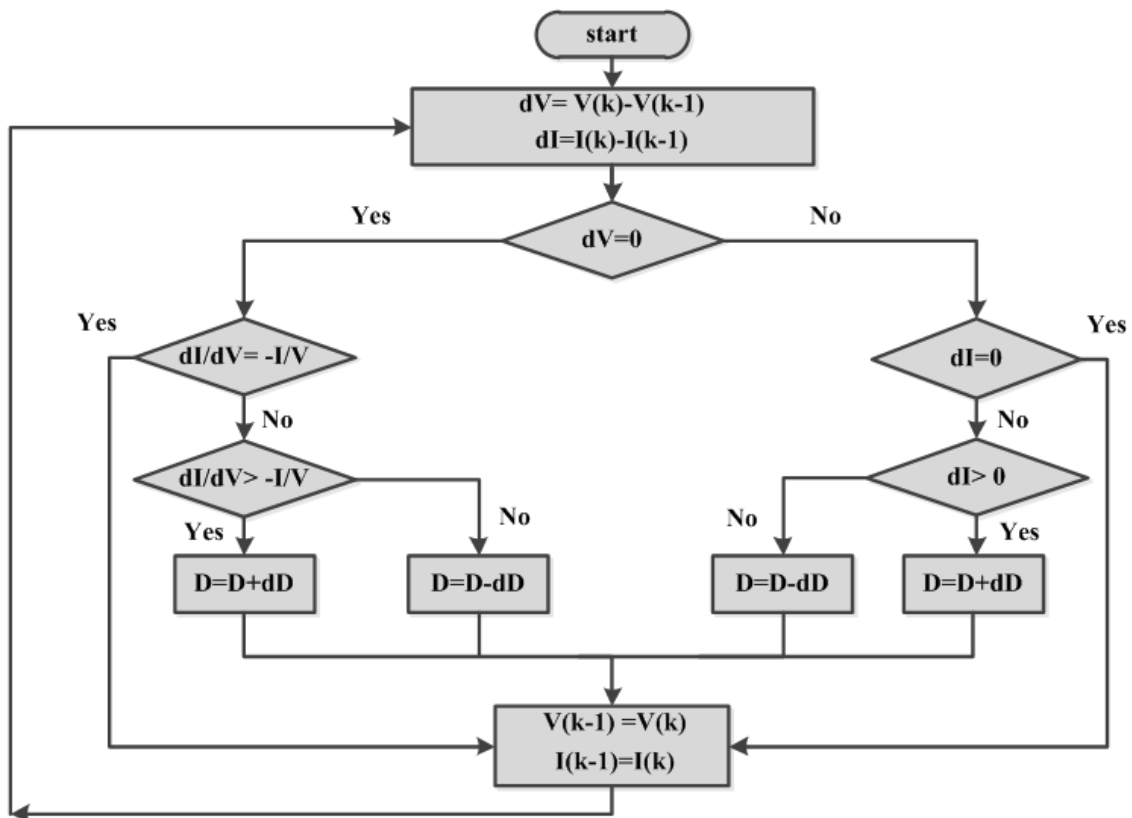

Figure 7. The INC MPPT algorithm.

### 3. Modeling of MPPT Controller Using Proteus software

In this paper, the MPPT technique is developed by utilizing proteus software to tracking the MPP and obtain the maximum power from the PV panel. Figure 8 shows the overall block diagram of the PV system using the flyback converter and MPPT technique. The PV system consists of a solar PV module, flyback converter, MPPT technique and resistance load.

The PV current is sensed using a INA169 analog DC current sensor while the PV voltage is measured using a voltage divider sensor. These PV parameters feeds to the Arduino microcontroller pins to implement the MPPT technique and then it's provided a PWM signal to the main MOSFET of flyback converter across to drive opt-coupler IC (PC 817) circuit. The main target of the MPPT technique is to process the signals from the two sensors to adjust the duty ratio of the flyback converter to extract the maximum power from the PV module to the load at different temperature and irradiance. In this paper, the flyback converter is utilized to optimize the extracted power from the PV module by using the MPPT technique. The DC-DC converter is connected between the PV module and the resistance load. The MPPT technique works with the flyback converter to finding the optimal MPP of the PV module. The MPPT technique gives the appropriate duty cycle to the flyback converter to maintains the operating voltage and current at the MPP regardless of the solar irradiance and temperature.

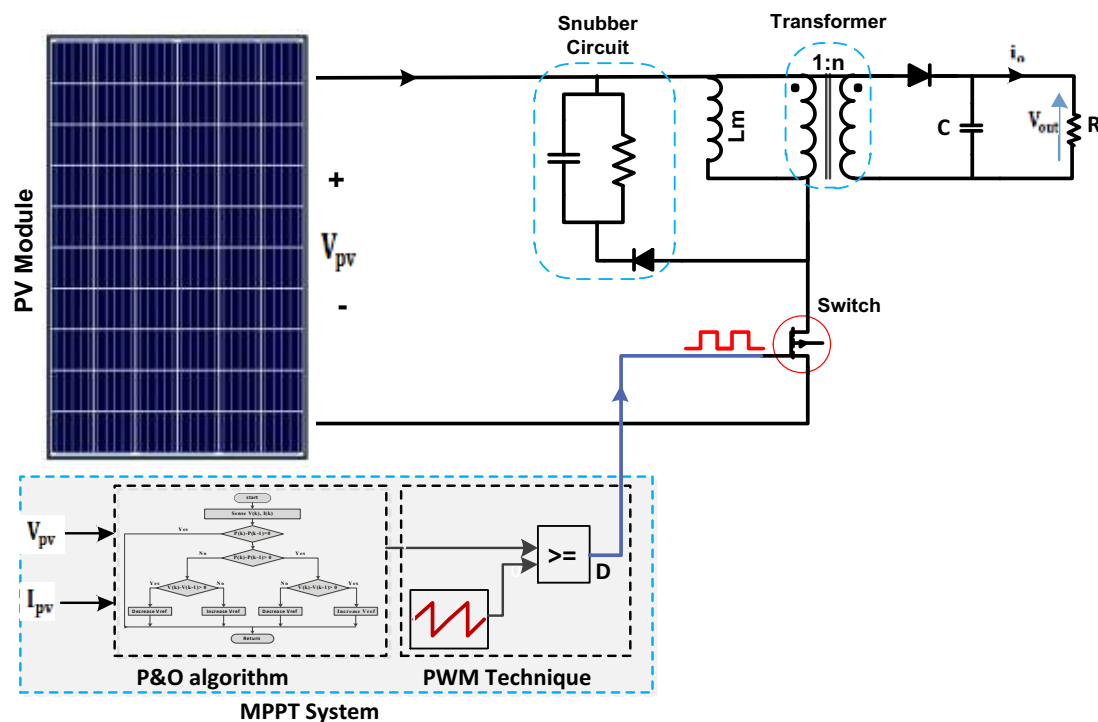
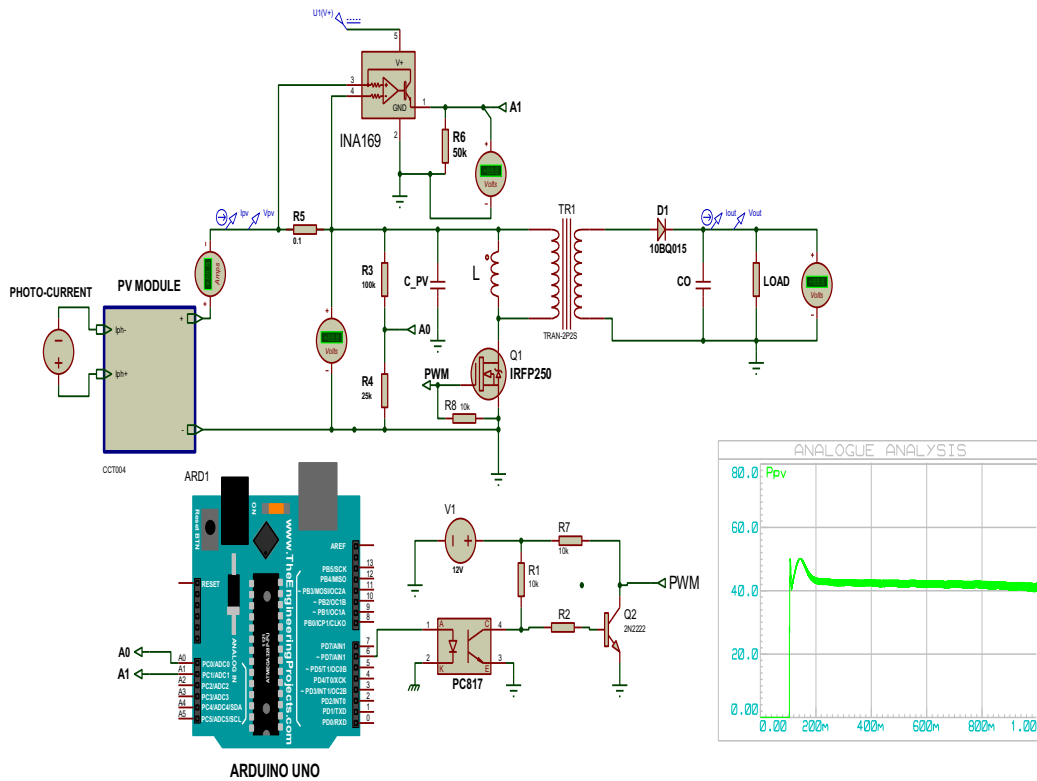

Figure 8. The overall diagram of the PV system based on the MPPT technique.

#### 4. Simulation Results

The simulation model of the PV system based on the MPPT controller using a flyback converter is implemented in Proteus software as shown in Figure 9. A Proteus is basically a software, which is utilized for the simulation of designing and drawing circuits, microcontroller and PCB designing. To model the PV module a “voltage controlled-current source” with a “DC voltage source” block is utilized. The DC voltage source has been set with a voltage at value is 21V to verify the photocurrent under standard conditions. Where the parameters for the PV model is represented in Proteus software by a particular spice code in Arduino UNO. The Arduino UNO is utilized with Proteus software to realize a compatible PV module model and written the MPPT code. The simulation of the PV module with P-V and I-V characteristics in Proteus is shown in Figure10. The work window of the Arduino program for MPPT code is shown in Figure 11. While the edit component to paste the MPPT code from the window of Arduino to Proteus software is shown in Figure 12. Figure 13 depicts the PV power for both INC and P&O MPPT techniques for stable irradiance ( $1000\text{W}/\text{m}^2$ ) at temperature ( $25^\circ\text{C}$ ). While Figure 14 depicts the PV power for both INC and P&O MPPT techniques for step-change in the irradiance from ( $1000\text{W}/\text{m}^2$ ) to ( $400\text{W}/\text{m}^2$ ). Figure 15 depicts the PWM signal for the flyback switch. The two MPPT techniques, (P&O) and INC are simulated and tested using Proteus software to investigate its performance. Where each technique is simulated with the PV model, flyback converter and load in order to the comparison between their performance. The results show that the P&O technique is tracked faster than the INC technique but the fluctuation is higher.



**Figure 9.** PV system based on MPPT Controller in Proteus software.

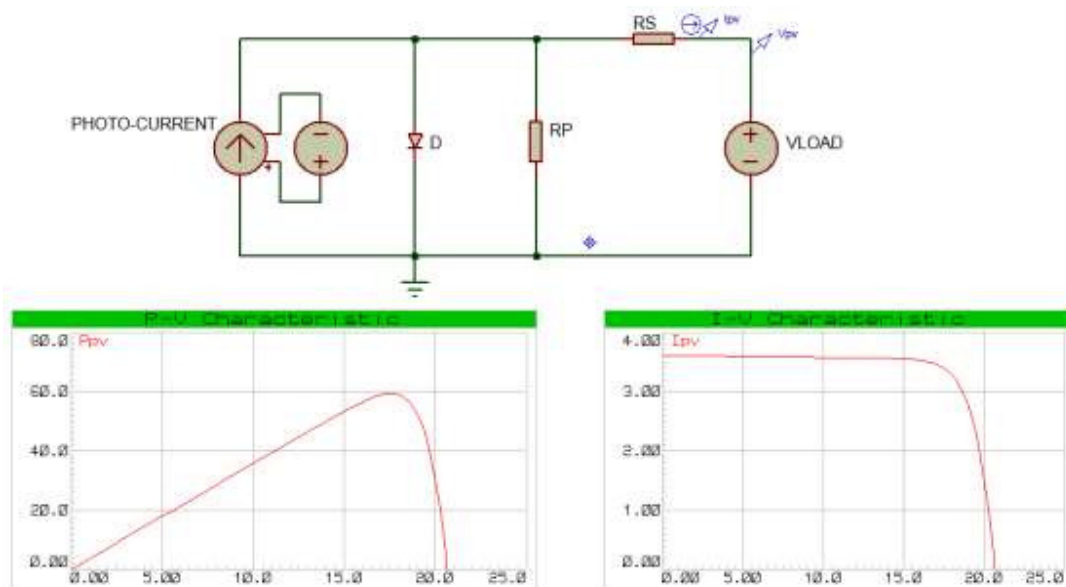

**Figure 10.** The PV module model with its characteristics in Proteus software.

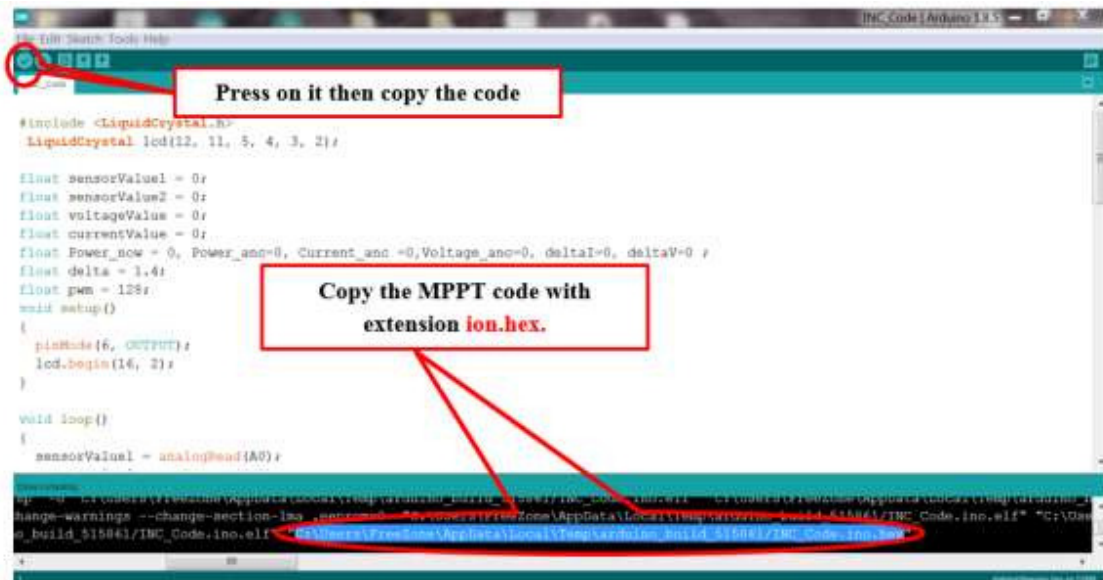

Figure 11. The work window of Arduino program

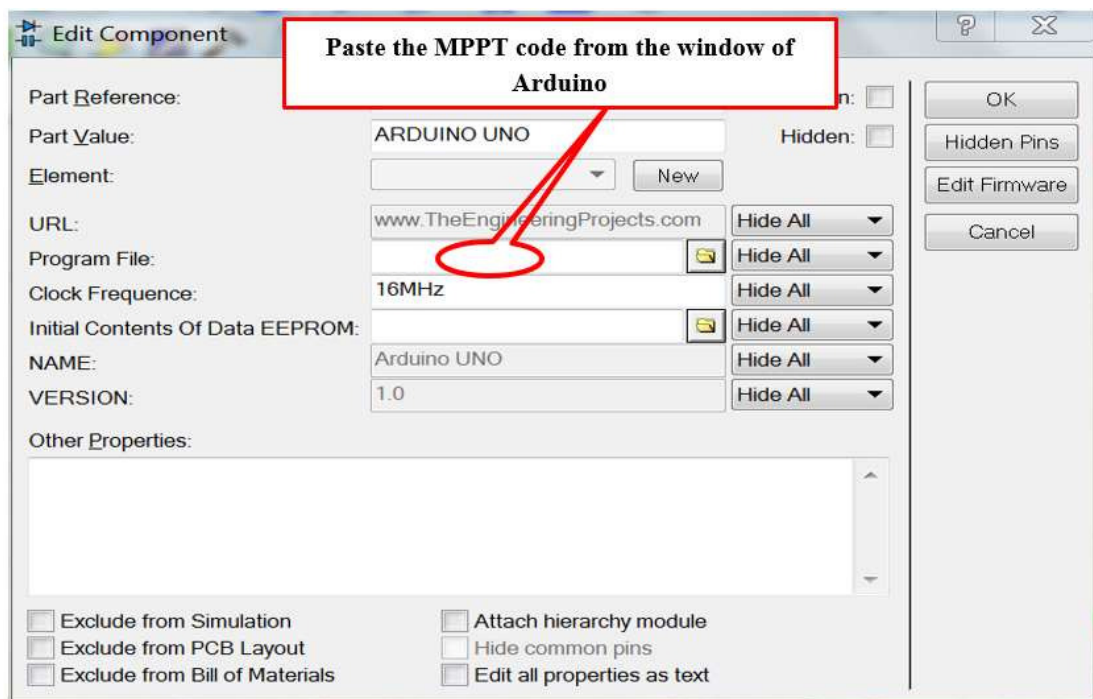
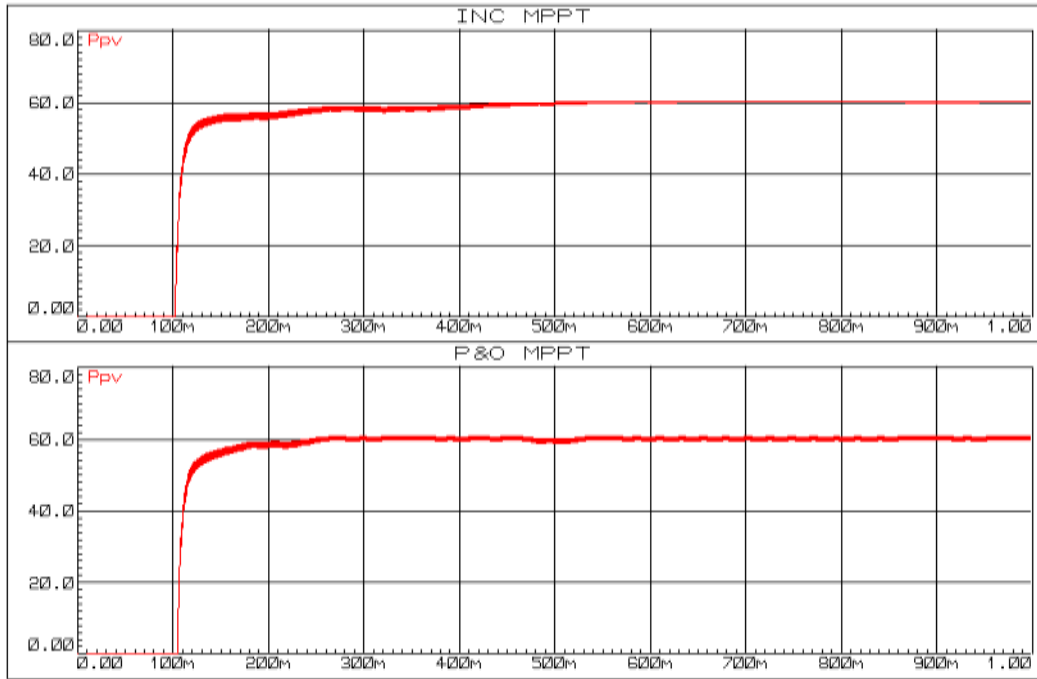
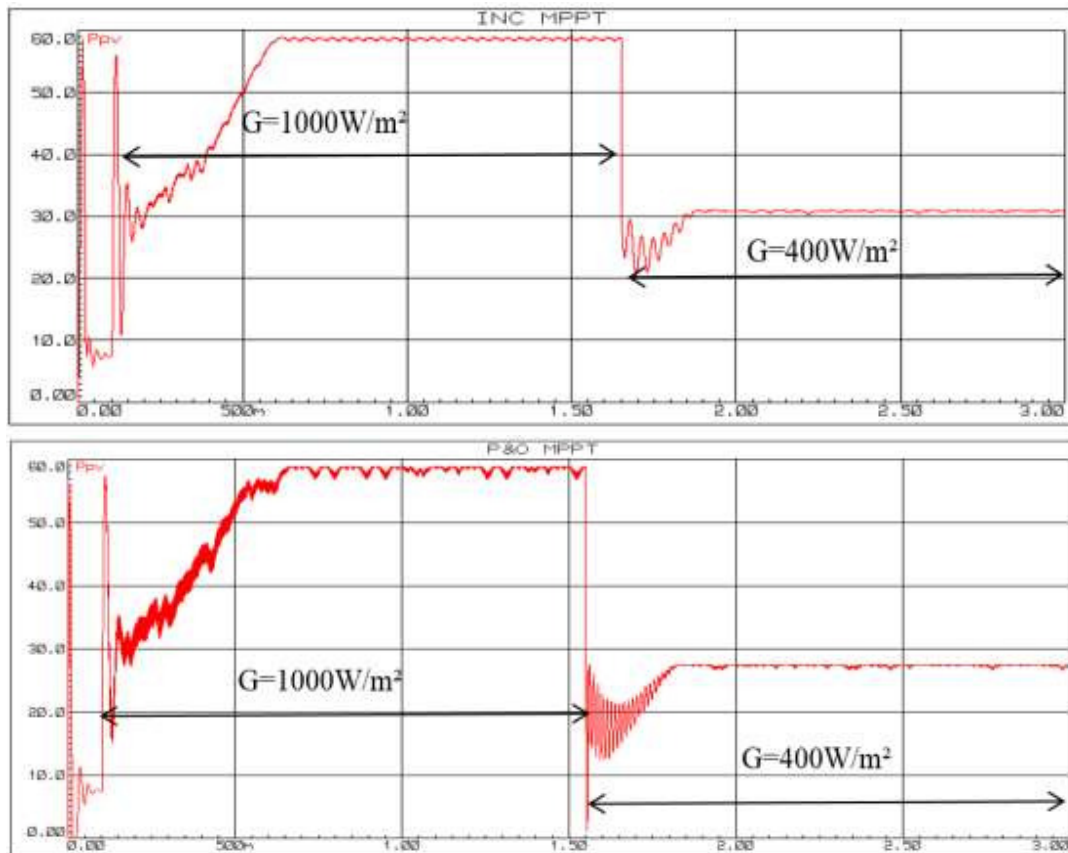

Figure 12. the edit component of Arduino in Proteus software.



**Figure 13.** The PV power for both INC and P&O MPPT techniques for stable irradiance.



**Figure 14.** The PV power for both INC and P&O MPPT techniques for step change in irradiance.

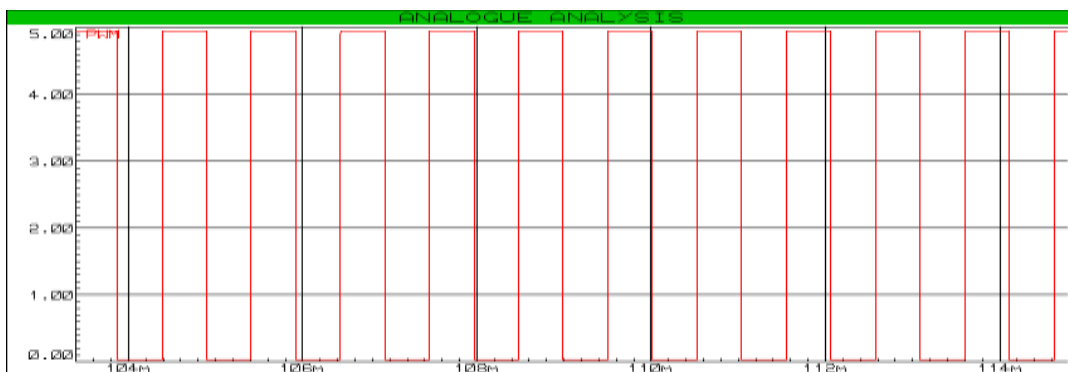

**Figure 15.** PWM signal for Flyback switch.

## 5. Conclusion

This paper presents the simulation design and verification of a Perturb-and-Observe (P&O) and incremental conductance algorithms based MPPT technique with a flyback dc-dc converter to elicit the maximum power of the PV panel using Proteus software. The simulation results demonstrate the two algorithms based MPPT technique to be effective and fast in maintaining the optimum operating point of MPP possible for different temperature and radiation conditions. In addition, depicts a perfect accomplishment of the operating point to the MPP operation with a stable voltage operation.

## References

- [1] Rokeya J. Mukti and Ariful Islam 2014 Designing an Efficient Photovoltaic System with Maximum Power Point Tracking algorithm by Comparing Different Converter Topologies, *7th Int'l Conf. on Computer and Information Technology*, Dhaka, Bangladesh, pp.235-240.
- [2] Ankit Gupta, Yogesh K. Chauhan and Rupendra K. Pachauri 2016 A comparative investigation of maximum power point tracking methods for solar PV system, *Solar Energy*, **136**, pp. 236–253.
- [3] Waleed I. Hameed, Baha A. Sawadi, Safa J. Al-Kamil, Mohammed S. Al-Radhi, Yasir I. A. Al-Yasir , Ameer L. Saleh and Raed A. Abd-Alhameed 2019 Prediction of Solar Irradiance Based on Artificial Neural Networks, *Inventions*, **4**(45).
- [4] Kashif I., Zainal S. 2013 A review of maximum power point tracking algorithms of PV system for uniform insolation and partial shading condition. *Elsevier, Renewable and Sustainable Energy Reviews*, **19**, pp. 475-488.
- [5] Waleed I. Hameed, Ameer L. Saleh, Baha A. Sawadi, Yasir I. A. Al-Yasir, and Raed A. Abd-Alhameed 2019 Maximum Power Point Tracking for Photovoltaic System by Using Fuzzy Neural Network, *Inventions*, **4**(33), pp. 1-12.
- [6] Mohamed A. E., Zhengming Z. 2013 MPPT algorithms for photovoltaic applications. *Elsevier, Renewable and Sustainable Energy Reviews*, **25**, pp.793-813.
- [7] A. Rezaee Jordehi 2016 Maximum power point tracking in photovoltaic (PV) systems: A review of different approaches, *Renewable and Sustainable Energy Reviews*, **65**, pp.1127–1138.
- [8] Pavels Suskis, Ilya Galkin and Janis Zakis 2014 Design and Implementation of Flyback MPPT Converter for PV-Applications, *Electric Power Quality and Supply Reliability Conference (PQ), Rakvere, Estonia*, pp. 291-296.
- [9] Ounnas, D., M., Ramdani, S., Chenikher; T., Bouktir 2017 An Efficient Maximum Power Point Tracking Controller for Photovoltaic Systems Using Takagi–Sugeno Fuzzy Models. *Springer, Arab J Sci Eng.*
- [10] Salam J. Yaqoob, and Adel A. Obed 2019 Modeling, simulation and implementation of photovoltaic panel model by proteus software based on high accuracy two diode model, *Journal of techniques*, **1**(1), pp. 39-51.
- [11] K.Sakthivel, V.Jayalakshmi and G.Rajakumari 2019 Modeling and Simulation of a GRID-TIED Solar PV System, *International Journal of Recent Technology and Engineering*, **7**(6S2), pp.537-543.
- [12] Mohammad Shadmand, Robert S. Balog and Haitham Abu Rub 2014 Maximum Power Point Tracking using Model Predictive Control of a Flyback Converter for Photovoltaic Applications, *2014 Power and Energy Conference at Illinois (PECI)*, Champaign, IL, USA,
- [13] Daniel P. Quesada 2018 Design and Construction of An Isolated Dc-Dc Flyback Converter for Solar Mppt Purposes, *Senior Thesis in Electrical Engineering University of Illinois at Urbana-Champaign*, pp.1-100.
- [14] Dong-Kyun Ryu, Bong-Yeon Choi, Soon-Ryung Lee, Young-Ho Kim, and Chung-Yuen Won 2014 Flyback Inverter Using Voltage Sensorless MPPT for Photovoltaic AC Modules, *Journal of Power Electronics*, **14**(6), pp. 1293-1302.