

PAPER • OPEN ACCESS

Structural behaviour of concrete beams reinforced with polyethylene terephthalate (PET) bottles wastes bars

To cite this article: Raad S. Falih *et al* 2020 *IOP Conf. Ser.: Mater. Sci. Eng.* **928** 022033

View the [article online](#) for updates and enhancements.



EXTENDED ABSTRACT DEADLINE: DECEMBER 18, 2020

239th ECS Meeting
with the 18th International Meeting on Chemical Sensors (IMCS)

May 30-June 3, 2021

SUBMIT NOW →

The banner features a red top section with white text, a dark blue middle section with white text and logos, and a light blue bottom section with white text. The ECS logo is on the left, and the IMCS 18th logo is on the right. The background of the middle section shows a network of nodes and lines.

Structural behaviour of concrete beams reinforced with polyethylene terephthalate (PET) bottles wastes bars

Raad S.Falih¹, Abbas O. Dawood² and Hayder AL-Khazraji³

¹Postgraduate student/Department of Civil Engineering, College of Engineering, University of Misan, Amarah, Maysan 62001, Iraq

²The Dean of College of Engineering, University of Misan, Amarah, Maysan 62001, Iraq

³Faculty at the Department of Civil Engineering, College of Engineering, University of Misan, Amarah, Maysan 62001, Iraq

¹Corresponding author e-mail: (raad079@gmail.com)

ABSTRACT

This paper examines the effect of using PET bottle waste as a reinforcement bar in concrete beams. Waste of PET bottles has been cut by a special tool to long strips with width of 6 mm and thickness of 0.5 mm and lengths ranging between 6000 mm for small bottles and 11000 for large bottles. Then, straps are used in the formation of PET bars in three different forms, two braids are formed and twisted bundles form. Each PET bar consists of 36 straps. PET bars are arranged in the same location of rebar as an alternative to the steel bars in the tensile area. Also, they are pre-tightened before casting with a special tool designed for this purpose in order to give it a straight texture and reduce the expected elongation. Five concrete beams with dimensions (150*200*1400)mm are used in this study. Two of them are controlled beams with and without tension steel reinforcement. The other three beams are reinforced with three different forms of PET bottle waste bars. The achieved results are encouraged and unprecedented as the models containing rods achieved a maximum failure load of up to 25% of the failure load for specimens containing reinforcing steel bars. This technique enhances its ability to be used as reinforcing bars in secondary structural members.

1. Introduction

PET plastic bottle waste is one of the most prevalent plastic waste at the global and local levels due to the nature of its use in the production of drinking water bottles and soft drinks, which is an important and vital part of human daily consumption. The demand and consumption of bottled water and soft drinks are directly proportional to population density, this also means an increase in the PET bottles waste that is discarded, which may increase significantly in the future as the population increases. The nature of PET bottles waste that are non-biodegradable and occupy large volumes of space compared to the other types of waste made it one of the largest problems facing the environment if not treated, will lead to widespread pollution in the near future. The volume of PET bottles waste represents now a large percentage of the total solid waste that is thrown in places of sanitary landfill, and it may have become the biggest challenge facing the environment and causes its pollution if not treated or recycled. One of the areas that occupied the researchers' interest is that the recycling of waste PET bottles in construction works. The researchers are using these wastes in different forms as fibers or as a partial substitute for fine or coarse aggregates in concrete mixtures. Few researches have attempted to investigate the properties of PET plastic bottles being non-degradable and



highly tensile strength in its use as steel bars replacement in structural members. In 2010, Kim et al [1], showed that used PET and polypropylene PP fibers as reinforcement for concrete beam enhanced tensile resistance, crack resistance, strain – hardening capacities, delayed macro-crack formation and raising the maximum mid-span deflection to approximately 400% compared to specimens without fibers. In 2013, Foti et al [2], used a three forms of a simply cutting PET bottle fibers as discrete reinforcement of specimens in substitution of steel bars the first form is 5mm circular fibers width, with weight percentages of 0.5%, 0.75%, 1.0% by of concrete. The second form is using long PET strips (half bottle) arranged in same position of steel bars in a concrete beams. The third form is a bottles strips with dimensions (45*0.2*300) mm. Their conclusions were improved the ductile behavior, concrete-PET adherence and that 1% is the ideal percentage of circular PET waste fibers. In 2014, Kumar et al [3] recycled PET fiber as in concrete beams with four types of specimens steel bars, without steel bars reinforcement, PET reinforcement, and combined steel and PET reinforcement. In the first type, the concrete beams made without any reinforcement, the second type is beam reinforced with PET hollow bars with 24 mm external diameter and 22.8 mm internal diameter, the third and fourth types are combination reinforcement beams with steel and PET in the tension zone. They found that all types are improved in flexural strength. In 2014, Foti et al [4], showed that the arranged PET recycled bottle as a grid for slab in long reinforcement discrete specimens as a substitution of steel bars gives concrete slabs a very ductile behavior and improved impact strength.

This study is differs from previous studies, being the first study that successfully used continuous, undivided, and pre-tensioned PET waste bars in three forms as a substitute for tension steel bars in (150*200*1400) mm reinforced concrete beams, in addition two beams are controlled with and without tension steel reinforcement for comparison. The application of the results of this study in real engineering works achieves a double benefit, which is ridding the environment of non-degradable PET bottle waste and providing non-corrosive plastic reinforcing bars that replace the reinforcing steel in the secondary structural joints. This study also is showed that PET bottle rods can be used as a substitute for reinforcing steel in non-bearing structural elements, and therefore can be used by following a series of procedures to facilitate their application to the ground.

2. Experimental Methodology

The work program includes studying the effect of using PET bottle waste that has been cut by special tool to the long straps as a pre-tension reinforcement bar on the behavior of concrete beams. Herein, five concrete beams with dimensions (150*200*1400) mm are used. Three beams are reinforced with three forms of PET bottle waste bars as a tension reinforcement and other two are controlled beams with and without steel reinforcement for comparison. Mechanical properties of concrete mixtures are also tested.

2.1 Materials

2.1.1. Cement

In this study, Ordinary Portland Cement Type I is used. Table(1) summarizes the physical properties. These properties are satisfied the requirements of the Iraqi Specification No. 5/1984 [5].

2.1.2. Aggregates

Natural sand that is brought from the Basra city in southern Iraq is used as a fine aggregate, with a maximum size of 4.75 mm. Crushed natural stone with a maximum size of 20 mm, is used as coarse aggregate. Tables 2, 3 and Fig.(1) show the grading for the two types of aggregates, which match the Iraqi standard Specification No.45/1984 [6].

2.1.3. Admixture

In this work, liquid super plasticizer (modified polycarboxylates based polymer) has been used which conformed to ASTM C494-99 types A and G [7].

2.1.4 Epoxy

High performance building adhesive epoxy based is used at the research type sikadur 31-41 cf slow. It is composed of two packs A and B that are mixed together to form a paste, as shown in Fig. (3-25). Adhesive for structural bonding is tested according to (ASTM, C881 M-02)[8], Type I, Grade 3, Class B + C[53]. Table (4) shows epoxy properties.

2.1.5 Steel Reinforcement

The deformed steel bars of 12.7 mm diameter are used for tension reinforcement and 10 mm diameter for shear reinforcement. The properties of reinforcing bars are showed in Table (5).

2.1.6 Polyethylene Terephthalate (PET)

Two commonly available forms of PET bottles are used in this study as a polyethylene terephthalate waste, small and large PET bottles. PET bottles with different sizes and colors were cut by a special tool into long straps with a width of 6 mm, a thickness of 0.5 mm, and a length between 6000 mm for small bottles and 11,000 mm for large bottles as shown in Fig.(2-a)and Fig(2-b). These straps are reconfigured into braids and long bundles resembling reinforcing bars. A tensile resistance test is performed for the PET bottle bars and it is found that one strip achieved a tensile strength of 77 MPa see Fig. (2-c).

Table 1: Physical properties of the cement

<i>Physical properties</i>	<i>Test result</i>	<i>Limits of Iraqi specification NO.5/1984[5]</i>
Fineness using blain air permeability apparatus (m ² /kg)	384	≥230
Setting time using Victa's method		
Initial (hrs: min.)	2:00	≥ 0:45 min
Final (hrs: min.)	3:45	≤ 10 hrs
Soundness using autoclave method	0.22	< 0.8
The compressive strength of mortar		
3Days, MPa	20.8	≥15
7Days, MPa	27.4	≥23
28 Days, MPa	34.7	

Table 2: A-Grading of the fine aggregate

<i>Sieve size (mm)</i>	<i>Sand percent passing %</i>	<i>Cumulative passing limits of Iraqi specification No.45/1984 [6]</i>
10	100	100
4.75	95.6	90-100
2.36	85.73	75-100
1.18	72.04	55-90
0.60	48.25	35-59
0.3	17.75	8-30
0.15	3.7	0-10

B- Physical Properties of Fine Aggregate

<i>Physical properties</i>	<i>Test results</i>	<i>Limits of Iraqi specification No.45/1984 [6]</i>
Specific gravity	2.56	-
Sulfate content %	0.13	≤0.5%
Absorption %	0.75	-

Table 3: Grading of coarse aggregate

Sieve size	%Passing	
	% Coarse Aggregate	Iraqi specification No. 45/1984[6]
37.5 mm	100	100
20 mm	97	95-100
10 mm	42.83	30-60
5 mm	3.145	0-10

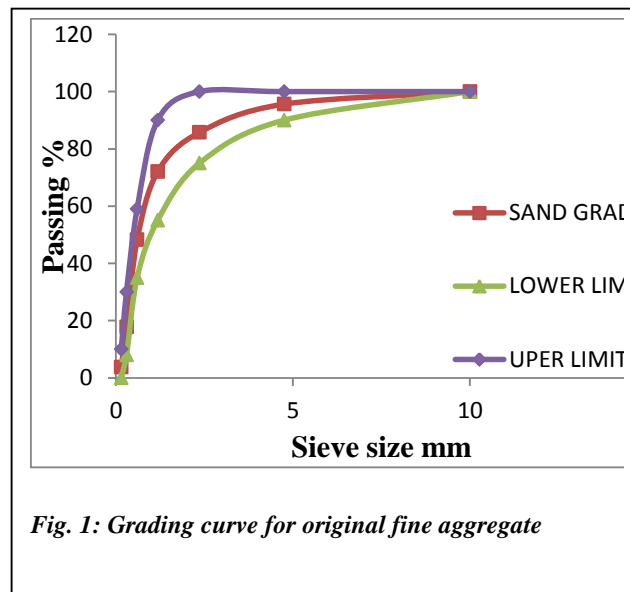

Fig. 1: Grading curve for original fine aggregate

Table (4) Chemical Base and technical proprieties of building adhesive epoxysikadur 31-41

Chemical base and technical proprieties	The determinants of epoxy	According to standard
Colour	Component A: grey, Component B: black Components A + B mixed: concrete grey	-
Shelf life	24 months from date of production	-
Density	1.93 ± 0.1 kg/l (component A + B mixed) (+23 °C) (evacuated)	-
Compressive strength	~52 N/mm ² (7d/ +25 °C)	DIN EN 196

Modulus of elasticity in compression	~2 600 N/mm ² (14 d / +23 °C)	ASTM D 695
Tensile strength in flexure	~27 N/mm ² (7 d/+25 °C)	DIN EN 196
Tensile Strength	~13 N/mm ² (7 d/+25 °C)	DIN EN 196
Modulus of elasticity in tension	~3 000 N/mm ² (14 d / +23 °C)	ISO 527
Elongation at break	0.6 ± 0.1 % (7 d / +35 °C)	ISO 527
Coefficient of thermal expansion	7.9 x 10 ⁻⁵ per °C (Temp. range +23 °C min. / +60 °C max.)	EN 1770
Mixing ratio	Component A: Component B = 2: 1 (by weight)	-

Table (5): Properties of Steel Reinforcement

Bar type	Bar diameter mm	Bar area mm ²	Yield strength fy (MPa)	Tensile strength fu (MPa)	Yield strain
Longitudinal steel bars & stirrups	10	78.5	515	624	0.00258
Longitudinal steel bars	12	113.04	493	583	0.00247



Fig.(2),a-PET bottle cutter tool, b- Cutting PET bottle method, c-Tensile testing of one PET strip.

2.2 Mixture Proportioning

common weight mixing ratios of (1: 1.5: 3) is used in this study to give an approximation to reality. The weight of cement, sand and gravel per cubic meter in this mixture are 444.75, 667 and 1334 kg, respectively with water cement ratio of 0.4 and 0.4% superplasticizer.

2.3 Preparation of Test Specimens

Fine and coarse aggregates are washed and cleaned before using in mixtures. All wooden molds consisted of a wooden base and four moving sides that are connected to the base with bolts and screws. As presented in Fig. (3) Wooden molds, cubes, cylinders and prisms are prepared, cleaned and lubricated before casting as shown in Fig. (3). PET bottle bars are placed in the tension area as an alternative to reinforcing steel in the molds, then the entire mold is placed on the pre-tensioning device and the ends of the PET bottle bars are attached to this tool to tighten it before casting. The

mixing process are started using an electric mixer by adding the aggregates of quality, then adding cement, water and additive. Mixing process is stopped at least two minutes after mixing.



Fig.(3) Preparation of Test Specimens

2.3.1 Type of reinforcement in concrete beams

Five reinforced concrete beams with dimensions (150 * 200 * 1400) have stirrups reinforcement of No.10 (#3) at 60 mm spacing, and of No.10 (#3) as anchorage bars to fix the stirrups. Tension reinforcement was variable for each beam. Two tension bars with different reinforcement details were used in this study as shown in Table(6) and Fig.(4) and Fig.(5), two of beams are reference, and they are as follows: -

1- **CC**: Without any reinforcement in the tensioning area.

2- **CR**: Reinforced with two steel bars of No.13 (#4) as tension reinforcement.

The other three beams are reinforced with PET bottle waste bars and they are as follows: -

3- **BP1**: - The bars of PET bottles are in the form of long braids, one braid consists of 36 strips, where each 12 long straps are manually braided separately to form a secondary braid, then each three secondary braids are manually braided to produce one main braid containing 36 strips with diameter of 14.7 mm. The concrete beam has two main braids that are placed as an alternative to steel bars in the tensile area. Then the ends of each PET braid are attached to the manual pre-tensioning device and tightened firmly before casting to ensure its straightness and reduce the expected elongation after applying loads.

4- **BP2**: Same as BP1 with the addition of an epoxy nodes of 8 cm length and diameter not exceed 20 mm, distributed at every 10 cm along the PET braid. This is done through the steps below.

A- pulling the braid tightly.

B- Surround and fix the perimeter of the knot with a wire mesh.

C- Fill it with the high performance building adhesive epoxy (sikadur 31-41 cf slow), making sure that the surface of the dough is rough. Fig. (6) shows the procedure of forming BP2 braids. The purpose of these nodes is to increase the bonding between the concrete and the braid, as well as to reduce the expected elongation in the braid when exposed to tension. These braids are attached to both ends of the pre-tensioning device exactly same as BP1 concrete beam.

5- **BP3**: PET bottle waste bars were in form of longitudinal main bundles. Each 12 strips were assembled to form secondary bundle then each three secondary bundles are assembled to form one main bundle consisting of 36 strips as shown in Fig. (4). Main longitudinal PET bundles that

are placed in the tensile area and tightly twisted to provide small grooves along the bundles, they increase the bonding with the concrete and prevent slipping. The twisting is done by connecting the ends of the longitudinal PET bundles to the serrated rods and then tightening them by nuts, where this process provides twisting and tightening the longitudinal PET bundles at the same time as shown in Fig.(7).

6-

Table(6) The detail of five beams that used in this part of study

no	Beam ID	Cross section	Dimension mm	Tension reinforcement
1	RC	Homogenous	1400 *200*150	Steel Rebar
2	BC	Homogenous	1400 *200*150	Shear Steel Rebar
3	BP1	Homogenous	1400 *200*150	PET Waste braids
4	BP2	Homogenous	1400 *200*150	PET waste braids with epoxy knots
5	BP3	Homogenous	1400 *200*150	PET Waste bundles



Fig. (4) a- Types of reinforcement for all concrete beams, b- type of PET waste bars

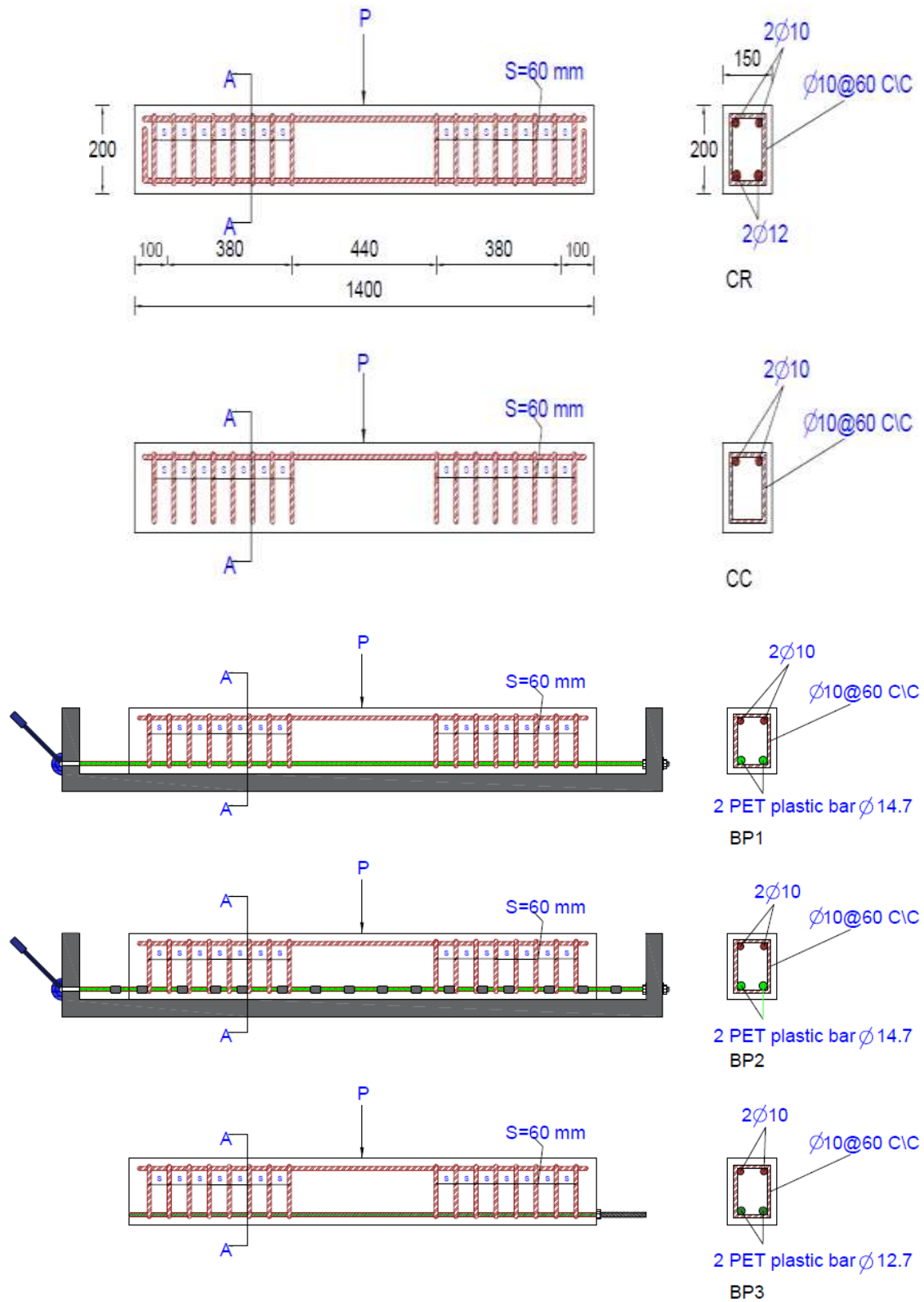

Fig.(5) Reinforcement detail for all beams



Fig. (6) Forming BP2 braids procedure

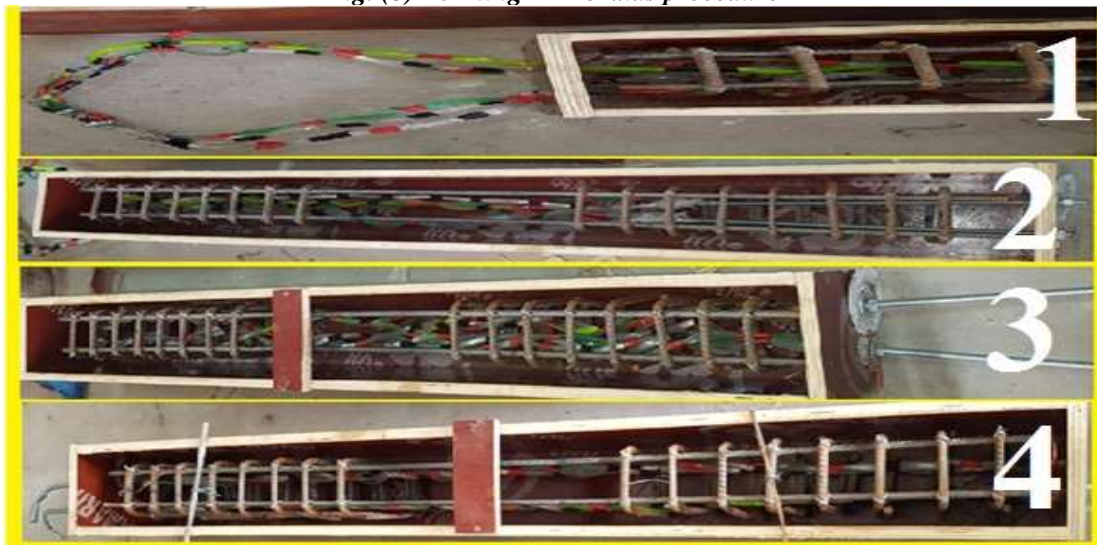

Fig. (7) Twisting and tightening BP3 bundles procedure

2.3.2 Pre- tensioning tool

This tool is made to pull the plastic PET bottle braids before casting to ensure its straightness and reduce elongation. Its consisting of a steel structure with a base and two ends perpendicular to the base. One end contains nuts to fix the first end of the braids as shown in Fig. (8). The second end contains a handle connected to the pull mechanism ,the braids is tied to it for tension process.

2.4 Laboratory tests

The mechanical properties of the concrete mix were tested, where six (150 * 150 * 150) mm cubes were used to test the compression resistance, six (100 * 200) mm cylinders to test the tensile strength resistance and six (100 * 100 * 500) mm prisms to flexural strength test at ages 7 and 28 days.



Fig. (8) Pre- tension tool details

Structural behavior tests for the five concrete beams are tested via ultimate failure load , ultimate deflection, ductility index, and stiffness

3.5 Results and Discussion

3.5.1 mechanical properties of concrete

The mechanical tests results of the of concrete (compression, splitting tensile, and flexural strength) at the age of 7 and 28 days are showed that the compression strength (49.8 and 53.6) MPa, splitting tensile (2.63 and 3.01) MPa ,and flexural strength (6.65 and 7.11) MPa, respectively as shown in Table (7).

Table(7) Results of compression, splitting and flexural strength at age 7and 28 days

Type of test	Age 7 days	Age 28 days
Compression strength MPa	49.8	53.6
Splitting tensile MPa	2.63	3.01
Flexural Strength MPa	6.567	7.11



Fig.(9) Mechanical properties specimens and testing method

3.5.2 Structural behavior of concrete beams

All reinforced concrete beams were designed according to ACI 318-95 [31] in a manner to ensure that the section fails in flexure with sufficient shear resistance, namely, withstand shear strength. Five concrete beams with dimensions (150*200*1400)mm are prepared to examine the impact of the PET waste on the reinforced concrete beams behavior via ultimate load, deflection at mid-span, cracking investigation, stiffness, and ductility as shown in Fig.(10).



Fig. (10): Beam specimens for the part of replacing main reinforcement

This test is done by an automatic compression machine with a capacity of 600 kN as shown in Fig.(12). One point load at the center of the beams was used and two supported with a clear span of (1200) mm between them. The loads were applied in sequential increments of 5 kN until reaching the failure load. Observations such as first crack, deflection, and drawing crack patterns at each load increment, were recorded. Dial gauge with an accuracy of 0.01 mm with a maximum reading of 5 cm was put beneath the mid-span of the beam to calculate the deflection reading for each beam at every load stage.

1-Ultimate failure load

The results of the ultimate failure load of all concrete beams are shown in Table(8) and Fig.(11). The reference reinforced concrete beam RC were achieved an ultimate failure load of 68.5 kN, while the unreinforced reference concrete beam CC recorded an ultimate failure load of 5.1 kN. The concrete beams BP1, BP2, and BP3 which were reinforced with PET bottle waste bars, recorded an ultimate failure load of 15.1, 13.3, and 16.8kN with ratios of 296%,260%, and329% as a percentages of plain concrete beam CC, while its recorded a ratio of 22%, 19.4%, and24% as a percentage of steel reinforced concrete beam CR respectively. These results are positive and encouraging because the reinforced concrete beams with PET bottles waste bars achieved a maximum failure load equivalent to a quarter of what the steel reinforcement concrete beams achieved, which enhances their ability to be used as reinforcement in non-bearing secondary structural members.

Table(8) ultimate failure load results for all beams

Beam ID	No. of reading	Ultimate load kN	Percentage with respect to (CC)	Percentage with respect to (CR)
CR	15	68.5	1343%	100%
CC	2	5.14	100%	7.44%
BP1	8	15.1	296%	22%
BP2	3	13.3	260%	19.4%
BP3	3	16.8	329%	24.5%

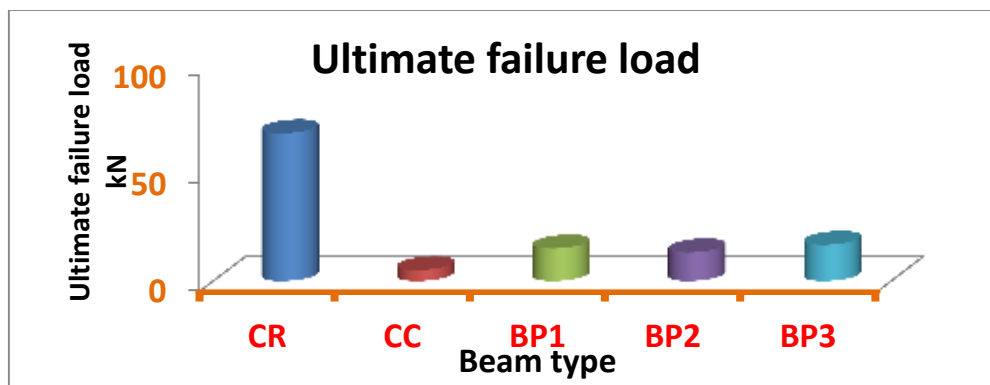
*Fig. (11): Ultimate failure load for all beam*

2-Maximum deflection

The results of the maximum deflection at failure load were shown in table (9) and Fig. (13). The steel-reinforced concrete beam CR recorded a max deflection of 23.5mm, followed by concrete beams BP1, BP2, BP3, and CC which recorded the ultimate deflection of 20.2, 0.96, 0.85, and 0.7mm respectively. The concrete beams CC, BP2, and BP3 exhibit a close and lowest deflection compared to concrete beams CR, BP1. It was also observed that in the case of releasing the load from the BP1 concrete beam, there will be a decrease in the reading of the dial gauge of 10 mm and a decrease ratio of 50% as a percentage of failure load deflection.

*Fig.(12):Beams specimens testing machine*

Table(9) Ultimate deflection results for all beam

Beam ID	Type of reinforcement	Ultimate deflection
CC	Without main reinforcement	0.7
CR	Steel reinforcement	23.52
BP1	PET waste reinforcement	20.2
BP2	PET waste reinforcement	0.96
BP3	PET waste reinforcement	0.84

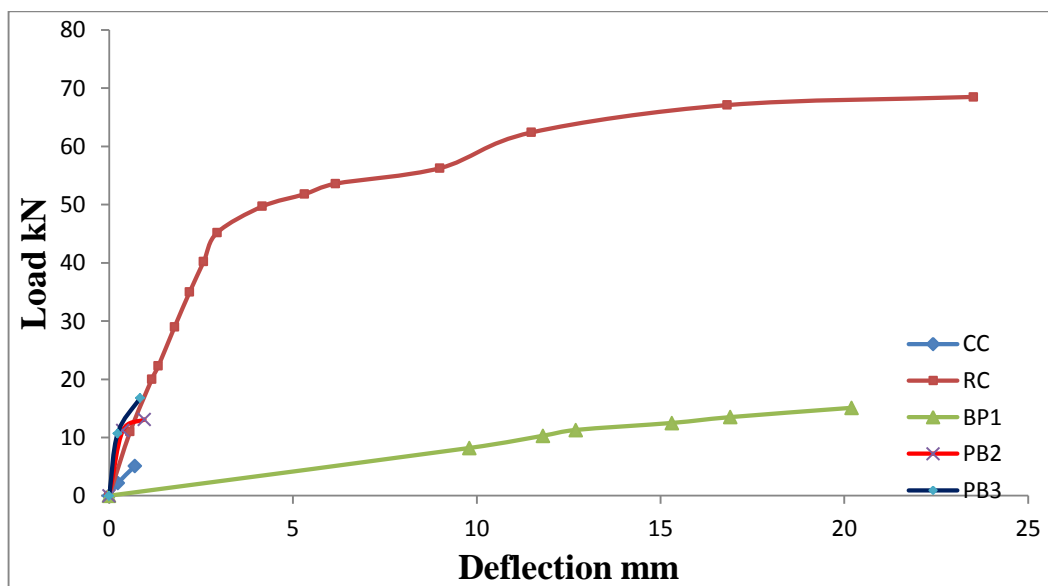
**Fig. (13) Load to deflection relation for all beams**

3- Stiffness

Initial stiffness and secant stiffness method (effective stiffness) were calculated from the load-deflection curve by dividing the maximum applied load (P_u) either on the yield deflection (D_y) in the initial stiffness case or on the ultimate deflection (D_u) in the secant stiffness case as shown in Fig. (16) according to past researches[9]. The result that presented in Table (10) and Fig. (14) showed that the reference concrete beams CR achieved an initial and secant stiffness of (14.28 and 2.9), while the concrete beams that reinforced with PET waste bars BP1, BP2, and BP3 are achieved an initial and secant stiffness percentages to steel-reinforced beam CR of (1.89%, 0.25%), (2.35%, 4.7%), and (3.12%, 6.8%) respectively. The concrete beams CR and BP1 recorded lowest initial stiffness, and secant stiffness respectively due to high deflection achieved by them. Although the beam BP3 which contains PET bundle bars has a quarter failure load of steel-reinforced reference beam CR, but it is achieved an optimum initial and secant stiffness due to very low deflection that was achieved by it. The same thing can be said to the beam BP2.

Table (10) Initial and Secant stiffness results for all beams specimens

Beam ID	Initial stiffness	Percentage to CR	Secant stiffness	Percentage to CR
CR	14.89	1	2.91	1
CC	8.2	0.55	-	-
BP1	28.27	1.89	0.75	0.26
BP2	35	2.35	13.8	4.7

BP3	46.52	3.12	20	6.8
------------	-------	------	----	-----

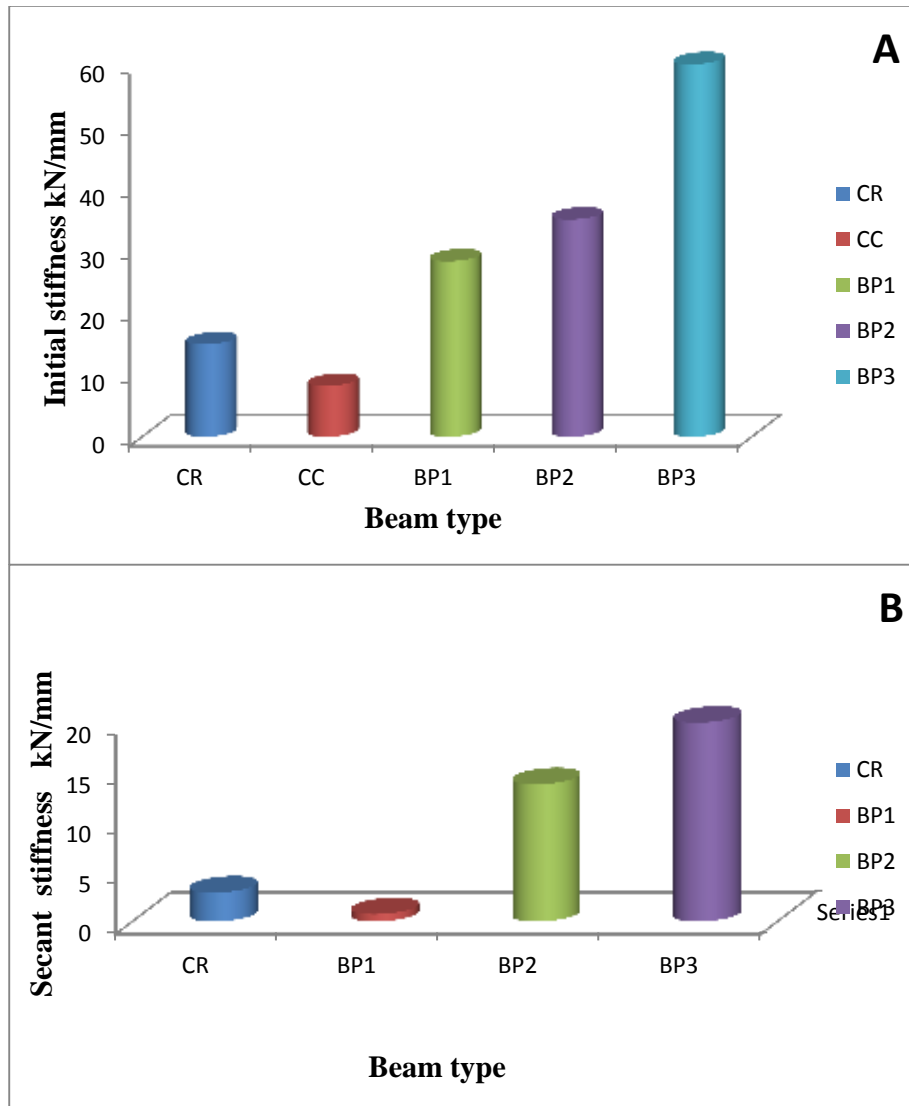

Fig. (14): A-Initial stiffness for all beam. B- Secant stiffness for all beam

4-Ductility index

The ductility index is determined from the load- deflection curve by dividing the ultimate deflection (Du) on the yield deflection (Dy) as explained in Fig. (16)[9]. The ductility index results of all beams show in Table (11) and Fig. (15).The results showed that the steel reinforced beam CR was achieved an optimum ductility index of 5.63, while the unreinforced concrete reference beam CC exhibited brittle behavior, as expected, with a ductility index of 1. The concrete beams BP1, BP2, BP3 which reinforced with PET waste bars, were achieved a ductility index of 1.59, 2.59, and 3.65 respectively, Almost 1-4 times greater than the ductility index of the reference beam without a PET bar. Notably, the PET waste bars are showed a good ductility impact compared to reference plain beam.

Table (11)Ductility index results for all beams specimens

Beam ID	Ductility index	Percentage to CR	Percentage to CC
CR	5.63	1	5.63

CC	1	0.17	1
BP1	1.59	0.28	1.59
BP2	2.59	0.46	2.59
BP3	3.65	0.64	3.65

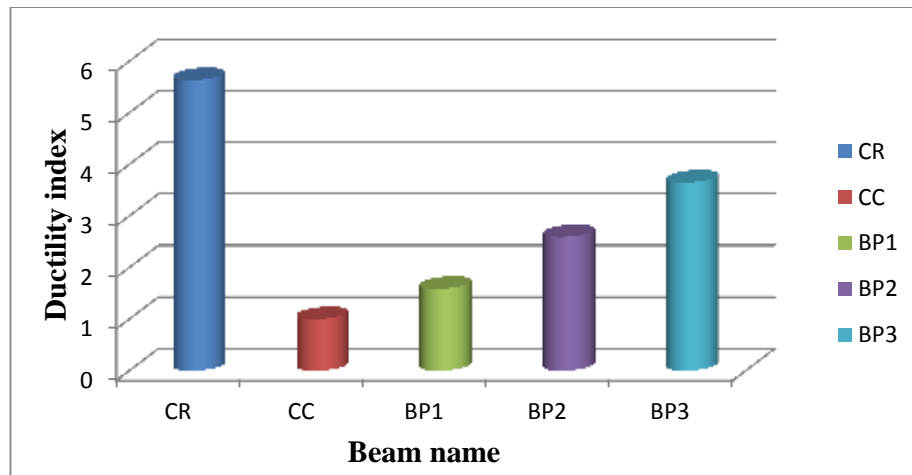

Fig. (15):Ductility index for all beam

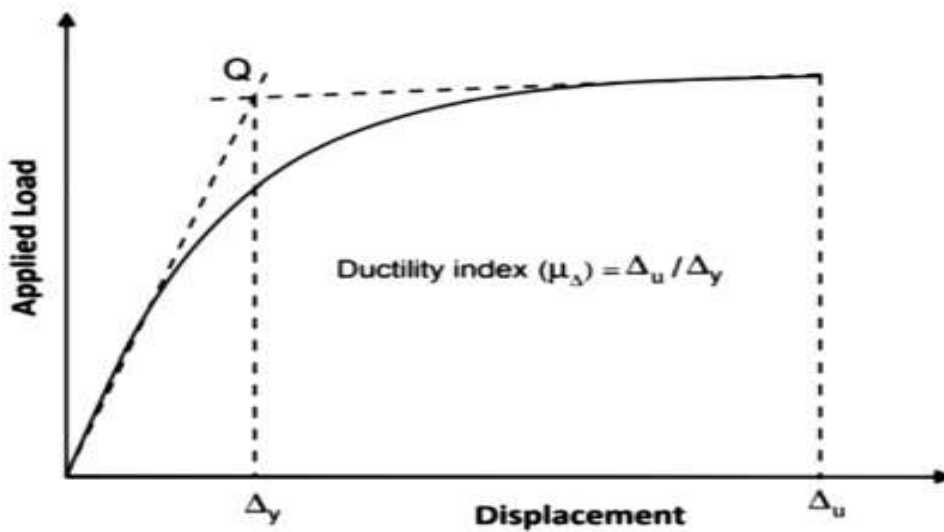

Fig.(16)The calculation method of Initial stiffness and Secant stiffness[9]

3-Cracks Pattern

All beams have a single crack appeared at the mid-span in the tension zone and increased until they reached to the compression zone except RC beam which has a set of cracks began at tension zone and tend to compression zone as shown in Fig.(17)



Fig. (17): Crack pattern of all beams specimens

Conclusions

This study concluded that:

- 1- The use of PET bottles waste rods as the main reinforcement in the tensile area of the concrete beams has achieved a ultimate failure load equal to three times of the failure load of the un reinforced concrete beams and a quarter of the failure load of the reinforced concrete beams with steel bars .The concrete beams (BP1, BP2, BP3) that reinforced with PET bottle waste bars, recorded an ultimate failure load equal to (296 ,260 , 329) % as a percentages of plain concrete beam, while its recorded a ratio of (22, 19.4, 24.5)% as a percentage of steel reinforced concrete beam respectively.
- 2- One of the reinforced concrete beams with PET bottles bars BP1 achieved an max deflection of approximate to the max deflection of the reinforced beam with steel bars CR, and deflection decreased by 50% when releasing the load. Unlike other concrete beams that were showed a lowest and close deflection.
- 3- The concrete beams BP1,BP2, and BP3 that reinforced with PET waste bars are achieved an initial and secant stiffness equal to(1.89%, 0.25%), (2.35%, 4.7%), and (3.12%, 6.8%) respectively, with percentages to steel- reinforced concrete beams, while the concrete beam BP1 recorded a lower secant stiffness due to its high deflection.
- 4- The concrete beams BP1, BP2, and BP3 which reinforced with PET waste bars were achieved a ductility index of, Almost 1-4 times greater than the ductility index of the reference beam CC without a PET bar. Notably the steel reinforced beam CR was achieved an optimum ductility index of 5.63.

References

- [1] Kim S.B., Yi N.H., Kim H. Y., Kim J.H..J., and Song Y.C. “ Material and structural performance evaluation of recycled PET fiber reinforced concrete “ Journal of cement & Concrete Composites, Elsevier, Vol.32, PP.232-240,2010.
- [2]Foti, D. (2013). Use of recycled waste pet bottles fibers for the reinforcement of concrete. Composite Structures, 96, 396–404. <https://doi.org/10.1016/j.compstruct.2012.09.019>
- [3] M.L.A.Kumar, Dr.I.V. Ramana Reddy, and Dr.C. Sasidhar ” Experimental Investigations on The Flexural Strength of PET Reinforced Concrete “ Journal of International Journal of Emerging Technology and Advanced Engineering,IJETAE,Vol.4,2014.
- [4] Foti D. and Paparella F. “Impact behavior of structural elements in

concrete reinforced with PET grids “Journal of Mechanics Research Communications, Elsevier, Vol.57, PP.57-66, 2014

[5] IQS 5/1984 “Portland cement Central Organization for Standardization and Quality Control Iraq” (in Arabic).

[6] IQS 45/1980 “Aggregates from Natural Sources for Concrete and Building Construction. Central Organization for Standardization and Quality Control”. Iraq (in Arabic).

[7] ASTM C494-99, "Standard Specification for Chemical Admixtures for Concrete", Annual Book of ASTM Standards, 2005.

[8]ASTM 2015 standard, title={Standard specification for epoxy-resin-base bonding systems for concrete}, author={ASTM}, journal={C881/C881M}, year={2015}

[9] Mustafa S. Abdulraheem, Experimental investigation of fire effects on ductility and stiffness of reinforced reactive powder concrete columns under axial compression, J. Build. Eng. 20 (2018) 750–761.